



# TBI Institute - Emissions

2019 Thomas Built Institute





**Cummins Just Changed the Game: Meet Their First Ever Gas-Powered Engine!**



# CUMMINS FIRST



# GASOLINE ENGINE

**Cummins First GASOLINE Engine is INSANE!**



# NEW EMISSION REGULATIONS?



NEW 2027 Cummins Diesel Engine EMISSION REGULATIONS are WILD \*\*Diesel Mechanic Explains\*\*



# EPA2004 levels

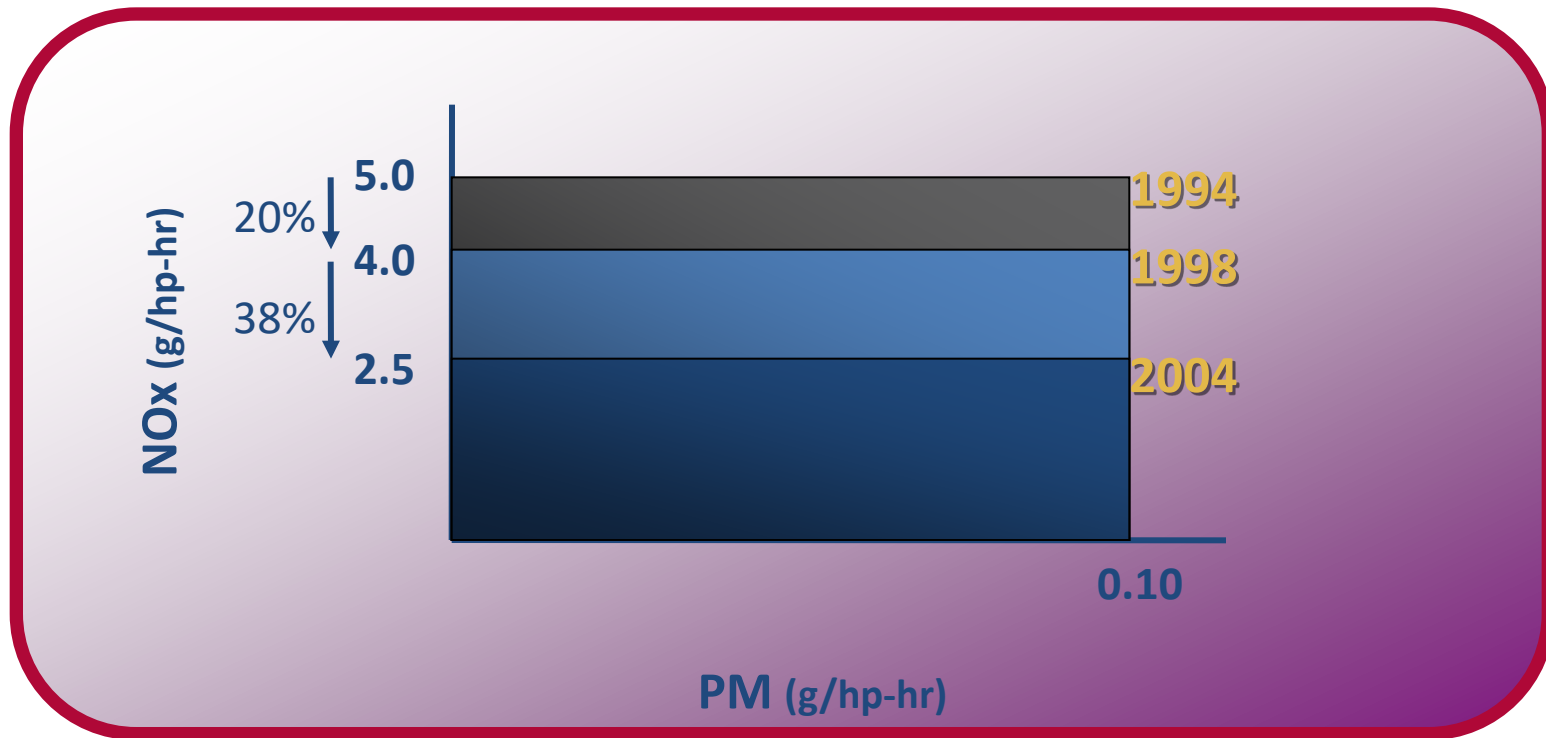

# EGR – Exhaust Gas Recirculation

- Simply put, it is the recirculation of exhaust back through the combustion process to help control emissions
- Very effective at controlling NOx emissions, but.....
- There are a couple of drawbacks:
  - 1) Using cooled exhaust means that the combustion event is less efficient
  - 2) That inefficiency results in greater particulate matter generation
  - 3) As you increase EGR levels you
  - 4) increase the need for cooling capacity

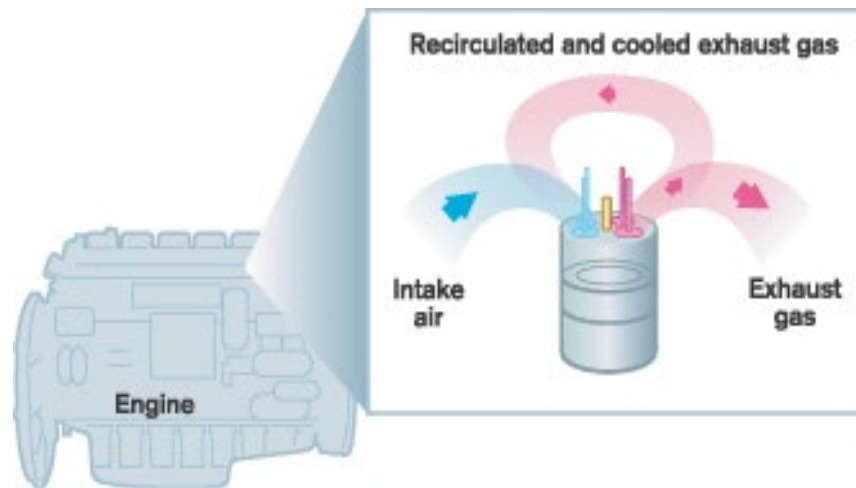

# The Aftertreatment Device

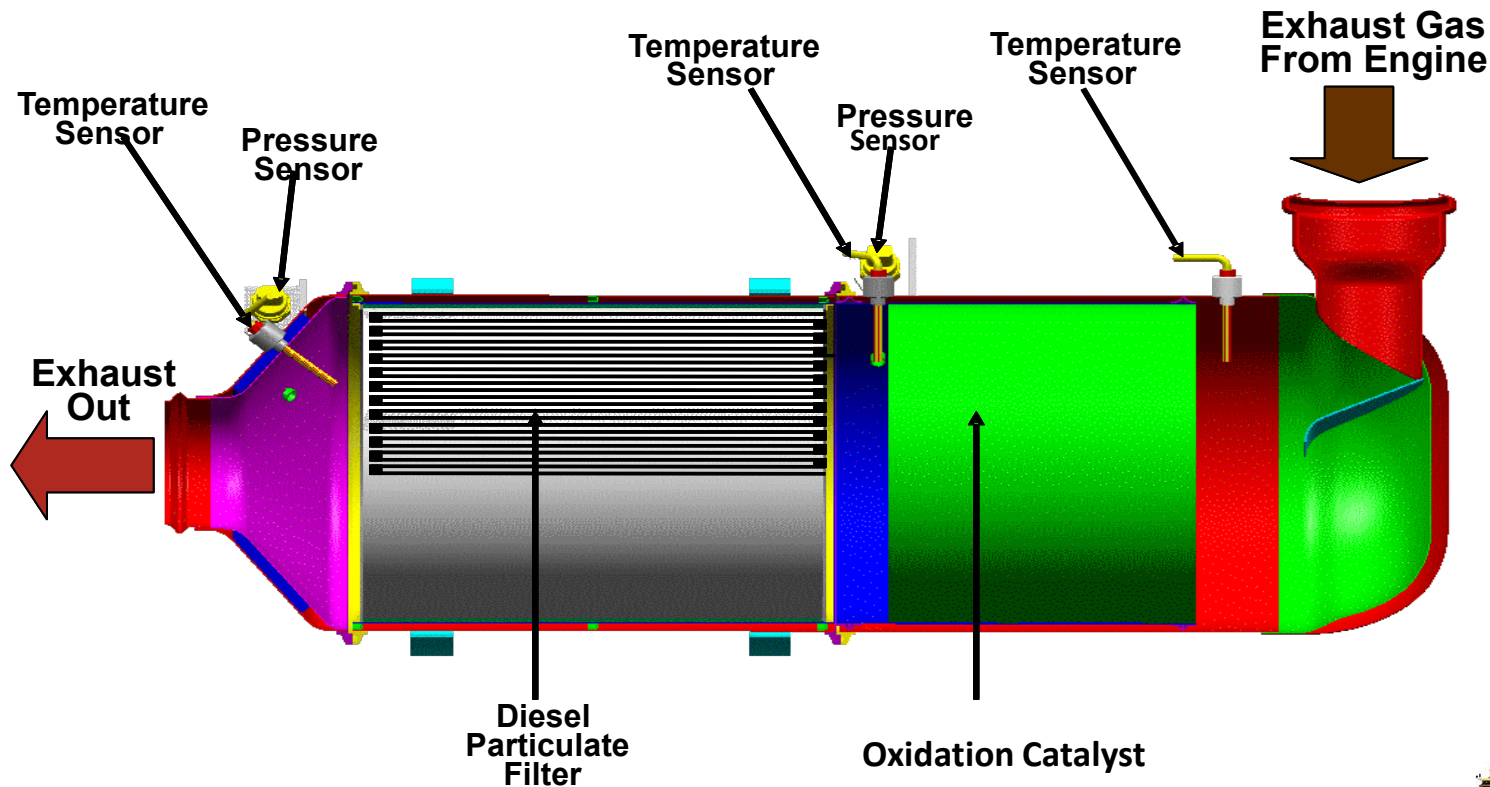

# The Regeneration Cycle

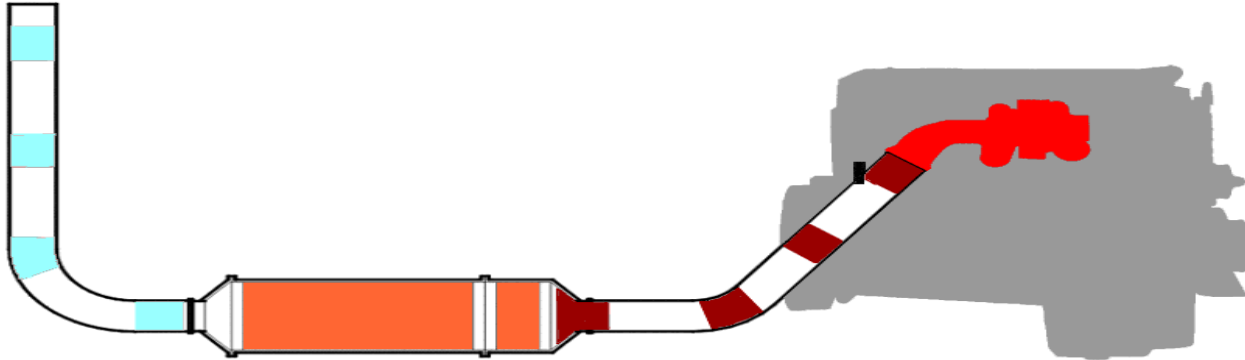

# Particulate Filter Structure

Surface Temperature does not exceed the surface temperature of a conventional muffler

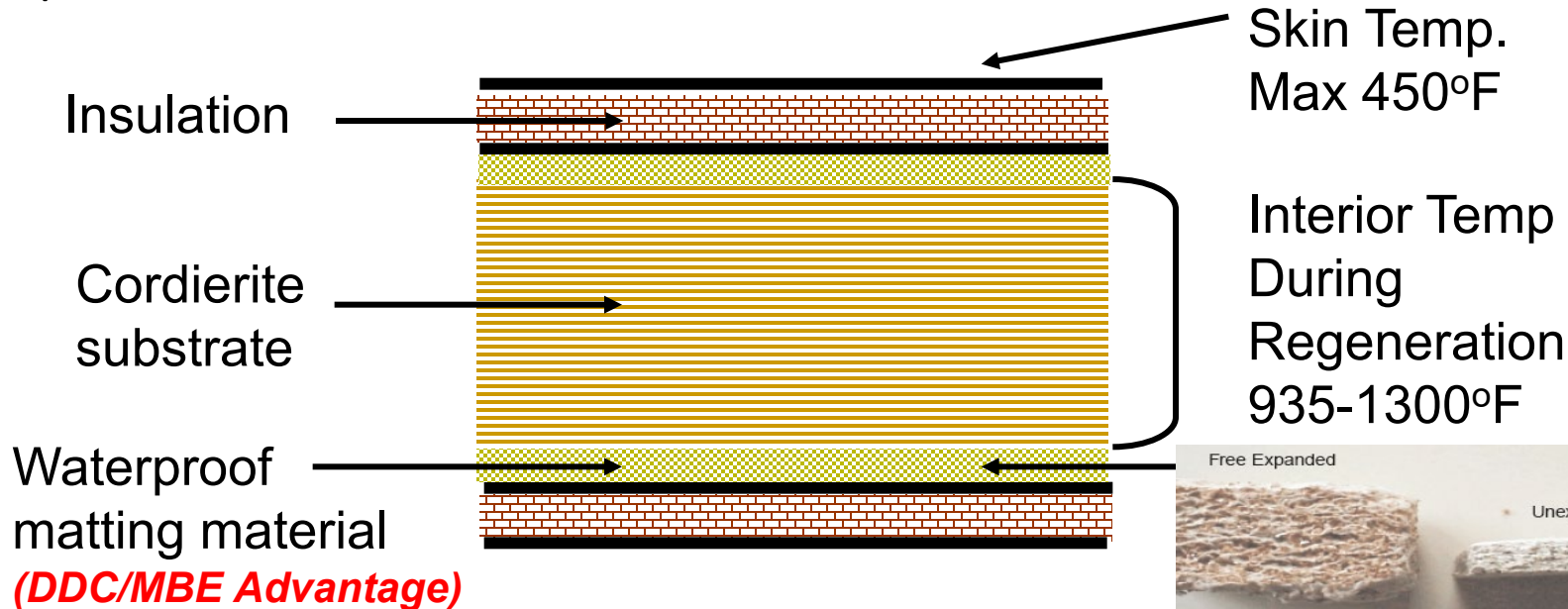

# Substrate Material Flow

Diesel Oxidation Catalyst

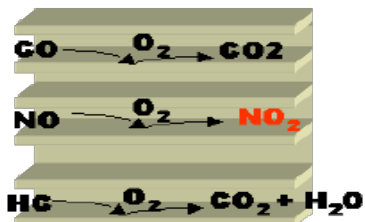

Flow Through Monolith



Diesel Particulate Filter

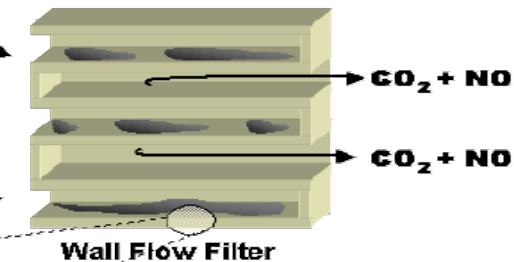

To Atmosphere

$\text{CO}_2 + \text{NO}$



# Aftertreatment Device Maintenance

- To change the filter loosen the V band clamps
- Use caution when changing this filter. Place a jack under it to support it and keep it from falling
- The unit is fragile and made of ceramic so do not drop it as that will damage the unit and cost you your core charge
- When the filter is full it will weigh up to 80 pounds!

Replacement interval is determined  
by pressure and  
will issue a code when needed

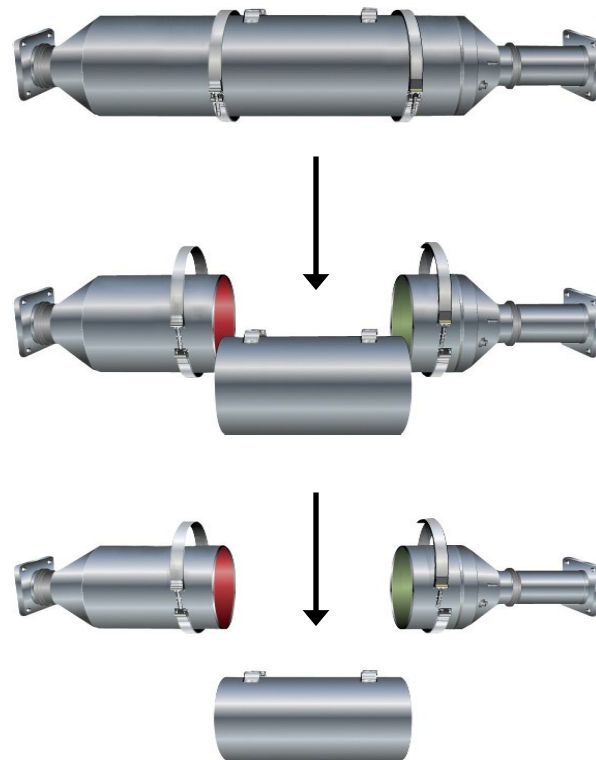

# Manual Regeneration Switch



**Parked  
Regeneration**

- Allows the Operator to:
  - Manually initiate an Active Regeneration while the vehicle is parked.
  - (optional service plug under the dash)

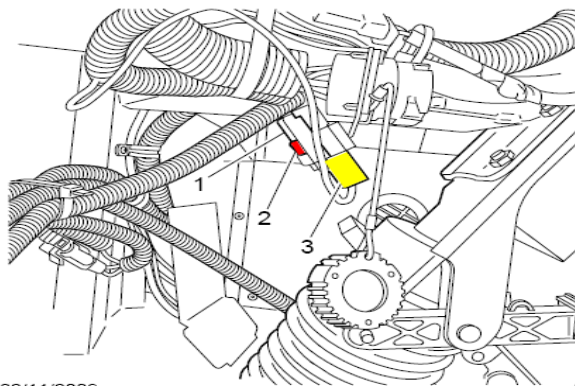

02/11/2009

1. Primary Lock
2. Secondary "Red" Lock
3. Plug



# Parked Regeneration FAQ

## How do I cancel a Parked Regeneration?

**Answer** – *To Cancel a Parked Regeneration hold the DPF Switch to the ON position for five (5) seconds and release.*

## Is there any other way to stop a Parked Regeneration?

**Answer** – *A Parked Regeneration will stop if the key is turned to the off position, the truck is put into gear, or the parking brake released.*

## What happens if I cancel a Parked Regeneration?

**Answer** – *If a Parked Regeneration is canceled, the driver has 15 minutes to restart the process to have it pick up where it was interrupted. If the 15 minute timer has expired then the Parked Regeneration will start over from the beginning.*

## How long will the High Exhaust System Temperature (HEST) Lamp Stay On?

**Answer** – *The High Exhaust System Temperature (HEST) Lamp will remain on until the exhaust temperature falls below 975F or the vehicle speed exceeds 5 mph.*

## When does the Idle Shutdown Timer Start?

**Answer** – *The Idle Shutdown Timer (if enabled) starts when Parked Regeneration is completed.*



# Parked Regeneration Procedure

Warm-up engine (coolant temperature above 185F)

Keep engine at slow idle (can not be in PTO mode)

Put transmission in neutral (cycle out of neutral and then back into neutral)

Set the park brake (cycle the park brake OFF to ON)

Press and release the clutch pedal (if configured)

Hold the DPF Switch to the ON position for five (5) seconds and release (engine speed will increase and DPF Lamp will go out)

A Parked Regeneration will take approximately 20-40 min. to complete

The regeneration is complete when the engine returns to slow idle and the DPF lamp remains off

If the DPF lamp comes back on the regeneration failed (Contact the Customer Support Center)



# Simulator

<i>Situation</i>	<i>Dash Lamps</i>	<i>Operator Action</i>
<p>Normal Operation Passive Regeneration</p>	<p>No Lamps On</p>	<p>Drive Normally</p>

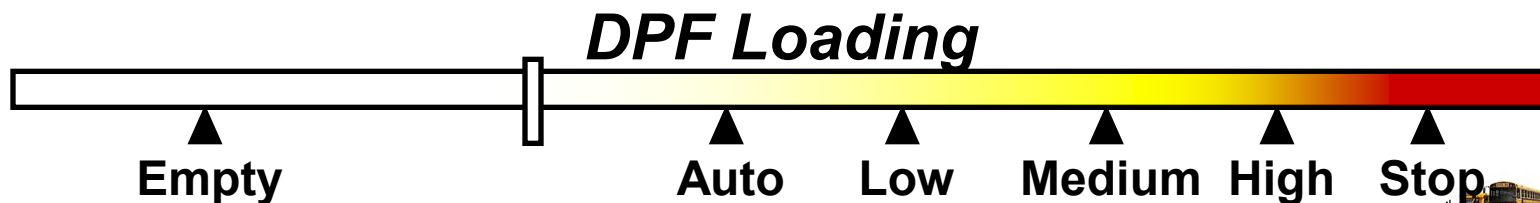

# Normal with Passive Regeneration

<i>Situation</i>	<i>Dash Lamps</i>	<i>Operator Action</i>
<p>Normal Operation</p> <p>Passive Regeneration</p>	<p>None</p>	<p>None</p>

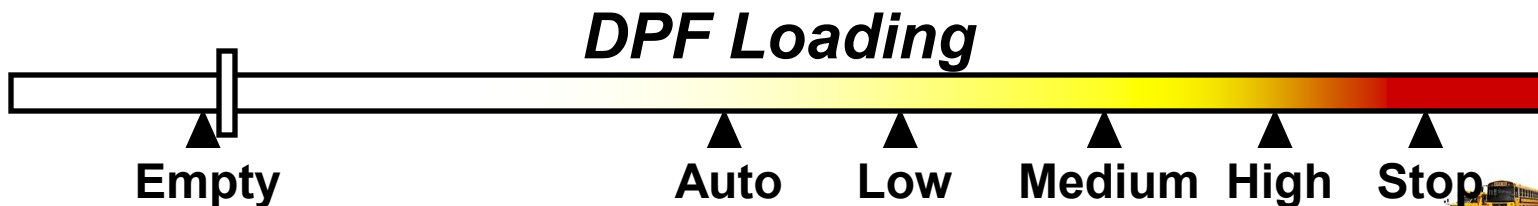

# Normal with Active Regeneration

Situation	Dash Lamps	Operator Action
<p>Normal Operation</p> <p>Active Regen.</p> <p>Above "Low Speed" Limit</p>	<p>HEST Lamp OFF (OEM dependent)</p>	<p>None</p>

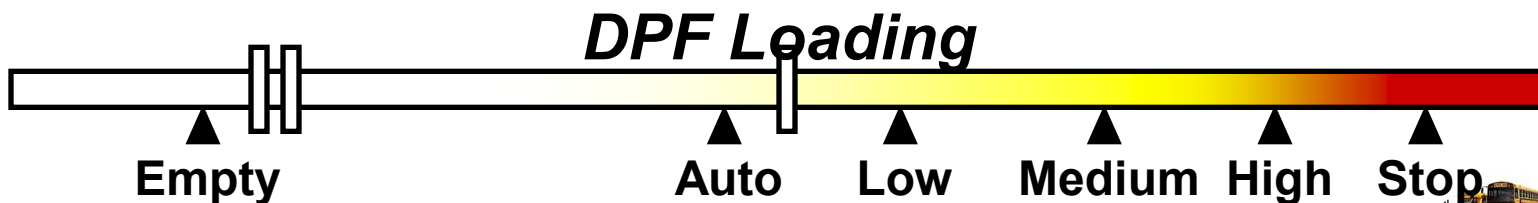

# Normal with Active Regeneration

<i>Situation</i>	<i>Dash Lamps</i>	<i>Operator Action</i>
Normal Operation Active Regen. Below "Low Speed" Limit	HEST Lamp On	Use Caution

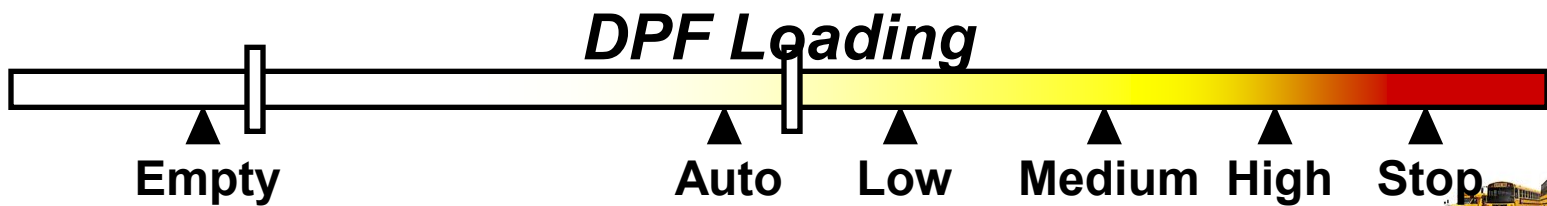

# Light Duty Cycle

<i>Situation</i>	<i>Dash Lamps</i>	<i>Operator Action</i>
Light Duty Cycle No Active Regeneration DPF Starting to Fill	DPF Lamp on	Regeneration (next 2-6 hours) Change Duty Cycle Parked Regeneration

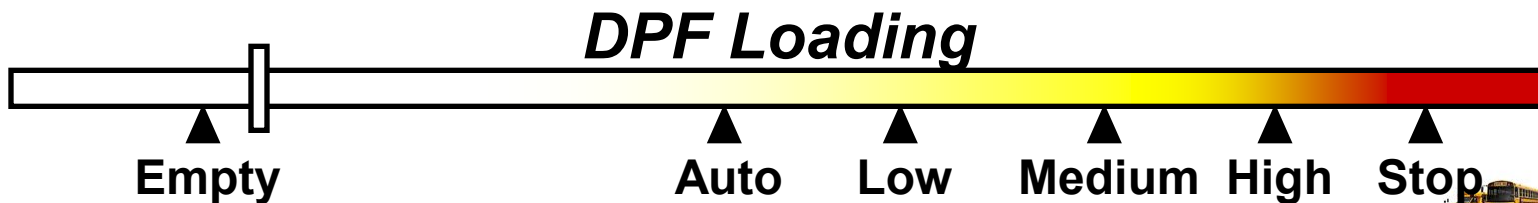

# Light Duty Cycle with No Regeneration

Situation	Dash Lamps	Operator Action
Light Duty Cycle No Regeneration DPF <u>Moderately Full</u> Slight Derate	DPF Lamp <u>Flashing</u>	Regeneration (next 1-2 hours) Change Duty Cycle Parked Regeneration

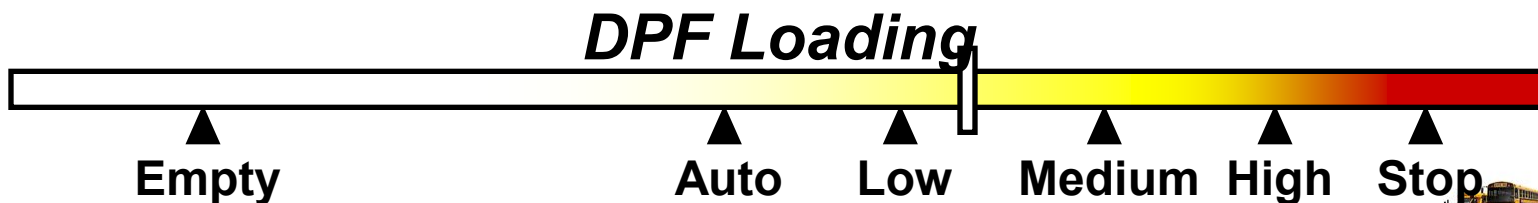

# Still No Regeneration

Situation	Dash Lamps	Operator Action
Light Duty Cycle No Regeneration DPF Almost Full Moderate Derate	DPF Lamp Flashing Check Engine Comes On	Regeneration <i>Immediately!</i> <del>Change Duty Cycle</del> Parked Regeneration

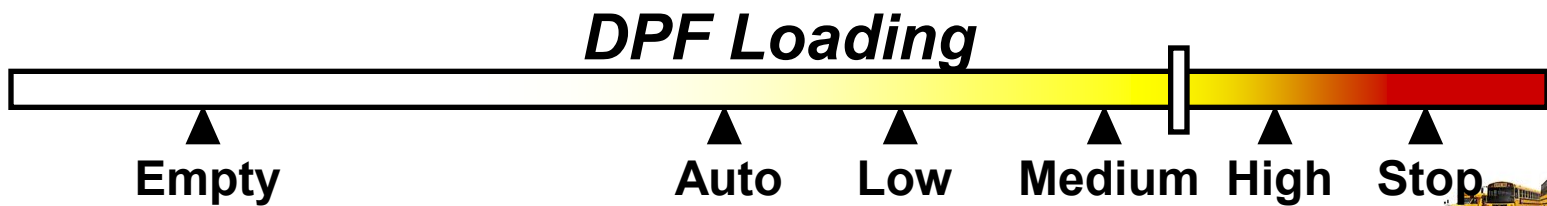

# DPF Full

<i>Situation</i>	<i>Dash Lamps</i>	<i>Operator Action</i>
<p>DPF <u>Full</u></p> <p>Severe Derate</p> <p>No Regeneration Allowed</p>	<p>Stop Engine Lamp Comes On</p>	<p>Stop Engine Immediately!</p> <p>Take Vehicle to Authorized Repair Location</p>

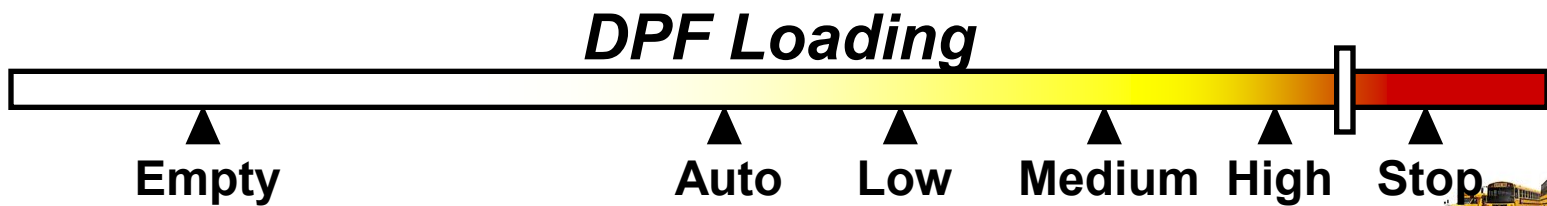
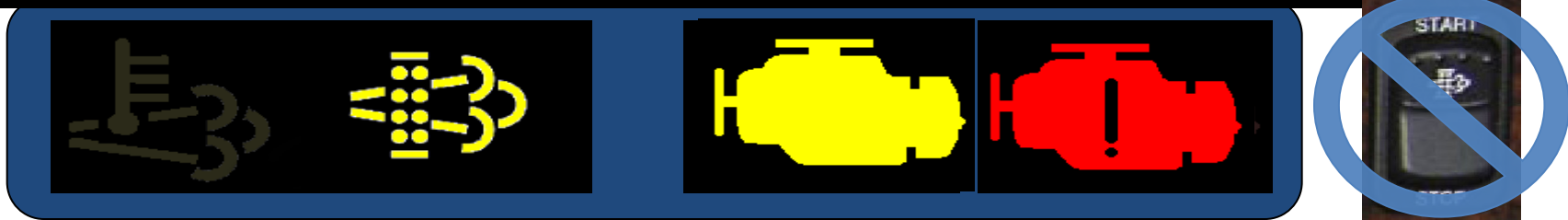

# Exhaust Temperature Testing

	Normal Operation	Regeneration
Pipe surface ahead of particulate trap	600-800 °F	600-1000 °F
Surface of the particulate trap	350°F	500°F
Pipe surface after particulate trap	600°F	900°F
Exhaust temp at exit of tailpipe	750°F	1150°F

Based on Heavy Duty Engine Testing



# Exhaust Temperature Testing

415°F Reduction in Max Temp @ 6" Away from Pipe

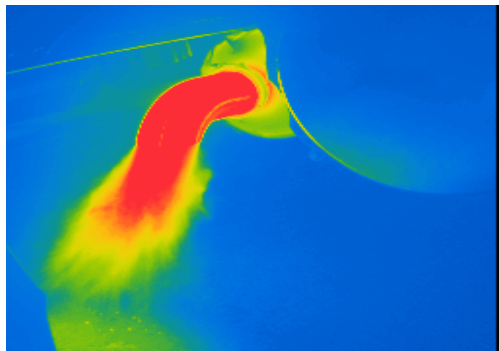

Stock Pipe  
Max Temp = 806°F / 430°C

*Make sure to replace  
damaged turn down  
with the correct part*

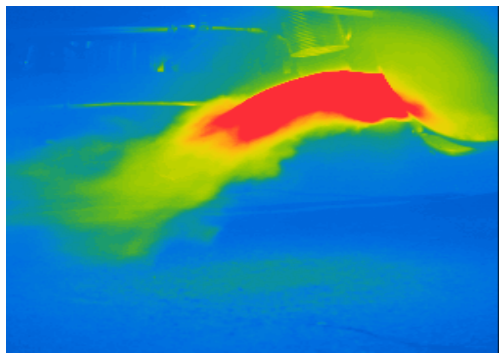

With Diluter Pipe  
Max Temp = 388°F / 198°C



# EPA2010 levels

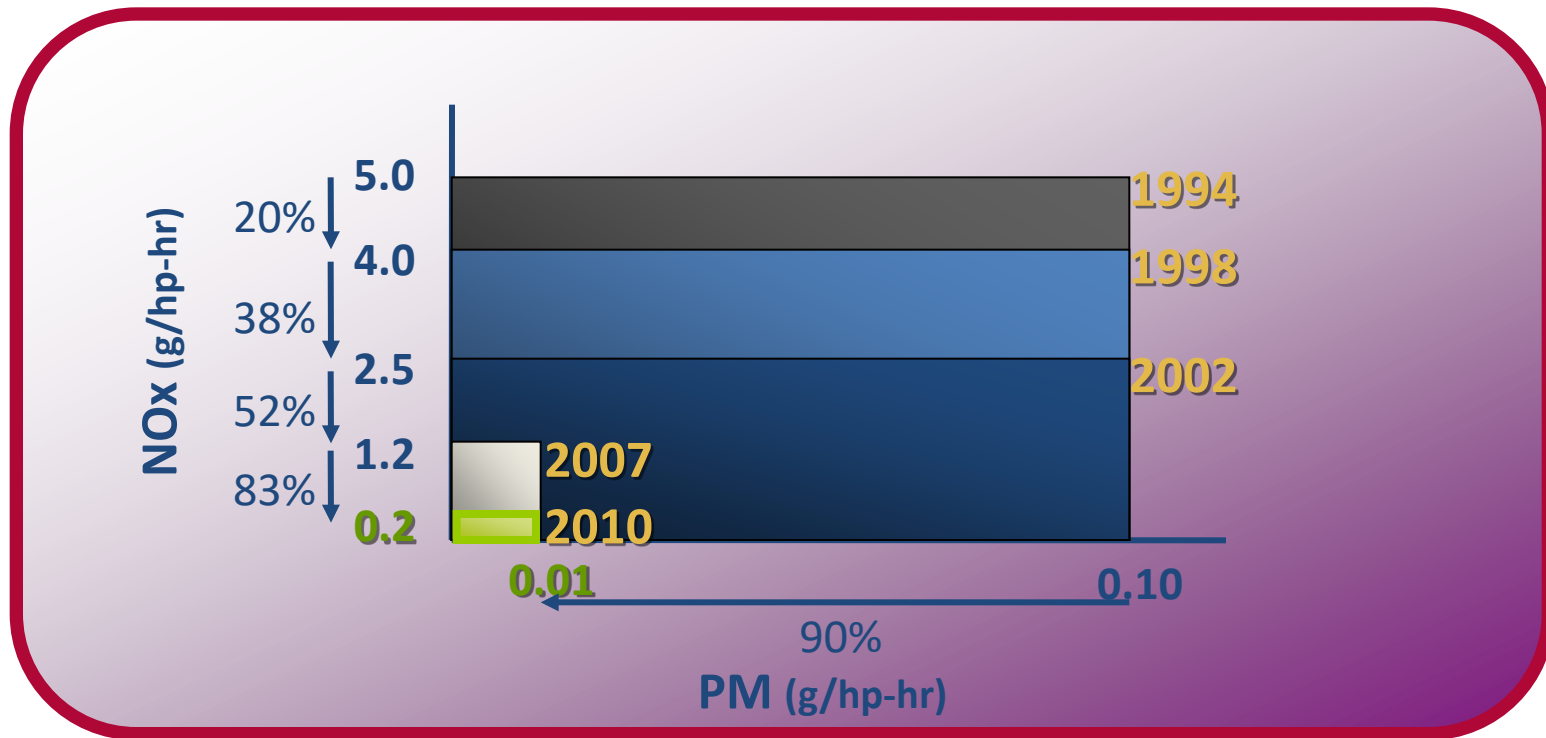

# EGR – Exhaust Gas Recirculation – still used

- Used in our engine offerings since 2004
- Simply put, it is the recirculation of exhaust back through the combustion process to help control emissions
- Very effective at controlling NOx emissions, but.....
- There are a couple of drawbacks:
  1. Using cooled exhaust means that the combustion event is less efficient
  2. That inefficiency results in greater particulate matter generation
  3. As you increase EGR levels you increase the need for cooling capacity

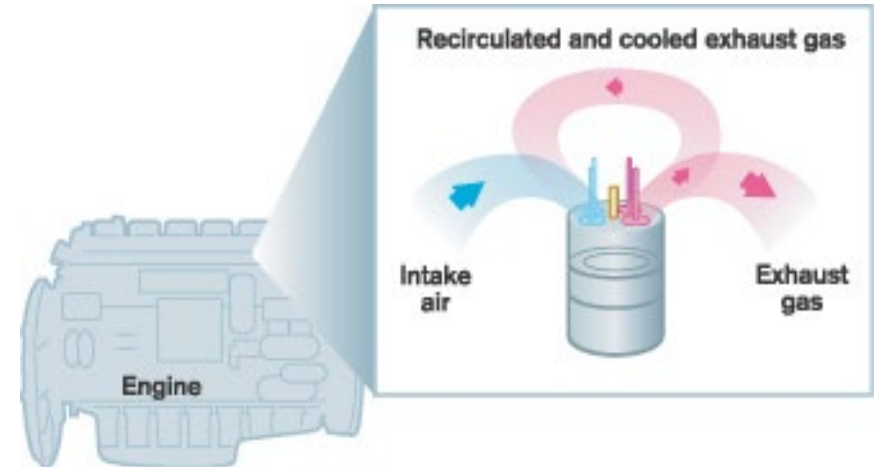

# Cummins 2010 ISB

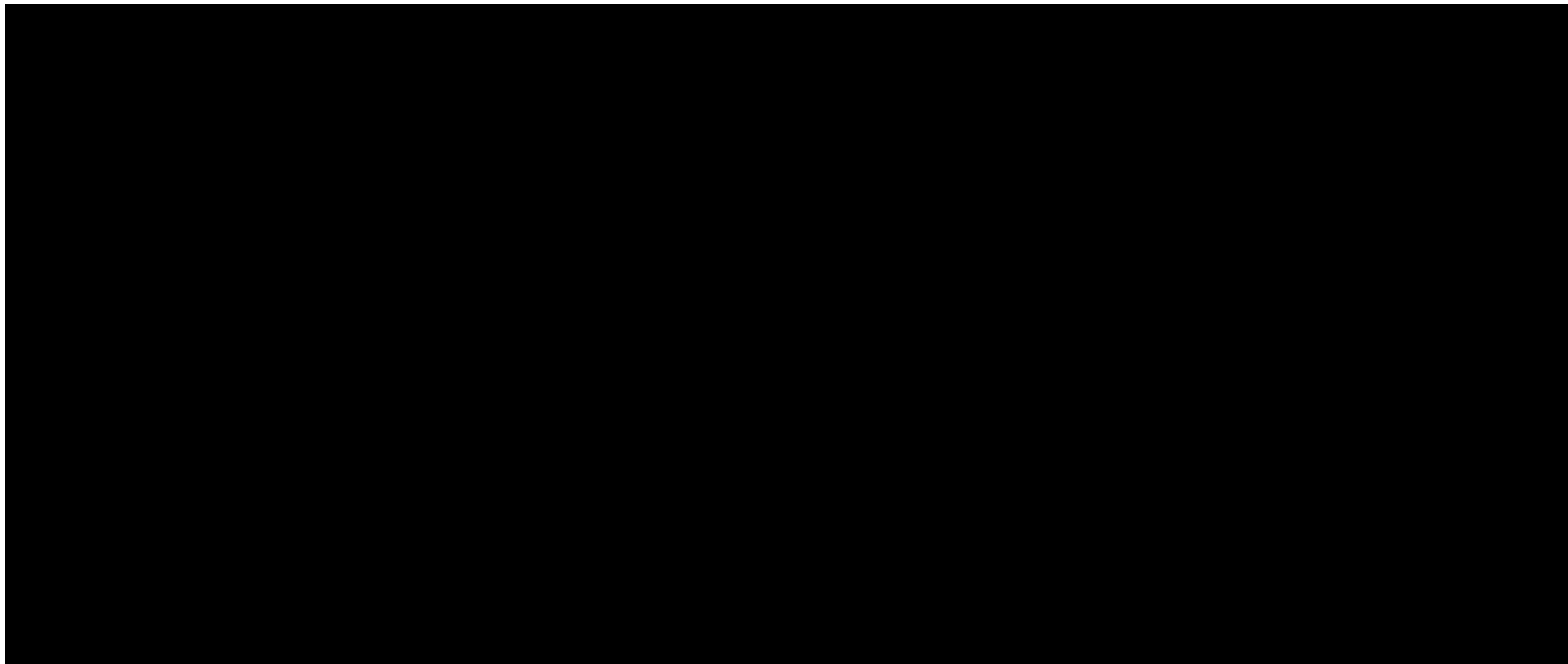

# SCR - Selective Catalytic Reduction

➤ What it is & How it works

1

## DEF Injection

- Small quantity of DEF injected
- Proportional to NOx rate
- 32.5% solution in water, freezing point =  $-11^{\circ}\text{C}$
- Stored in heated tanks
- $(\text{NH}_2)_2\text{CO}$

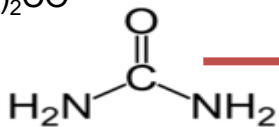

2

## Hydrolysis

- DEF breaks down by hydrolysis to form ammonia,  $\text{H}_3\text{N}$

DEF  
Injector

3

## NOx Catalyst

- NO and  $\text{NO}_2$  react with ammonia over a catalyst to form nitrogen ( $\text{N}_2$ ) and water vapor ( $\text{H}_2\text{O}$ )

NOx  
Catalyst

4

## Slip Catalyst

- Any trace amounts of ammonia remaining after reaction with NOx is broken down to nitrogen
- Maximum tailpipe ammonia 10PPM

Slip  
Catalyst



# Mild EGR + SCR Catalyst = Optimized Performance

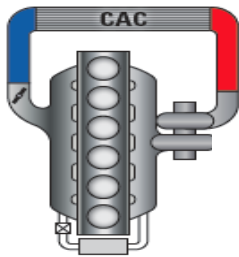

**ENGINE**  
with EGR

**Engine**  
**+ Mild EGR Rate**

---

**Better fuel economy**  
**Better performance**

**Introduced – 2002/04**

**Our path is the natural evolution of what was begun in 2002/04**



# 2010 Aftertreatment System Block Diagram

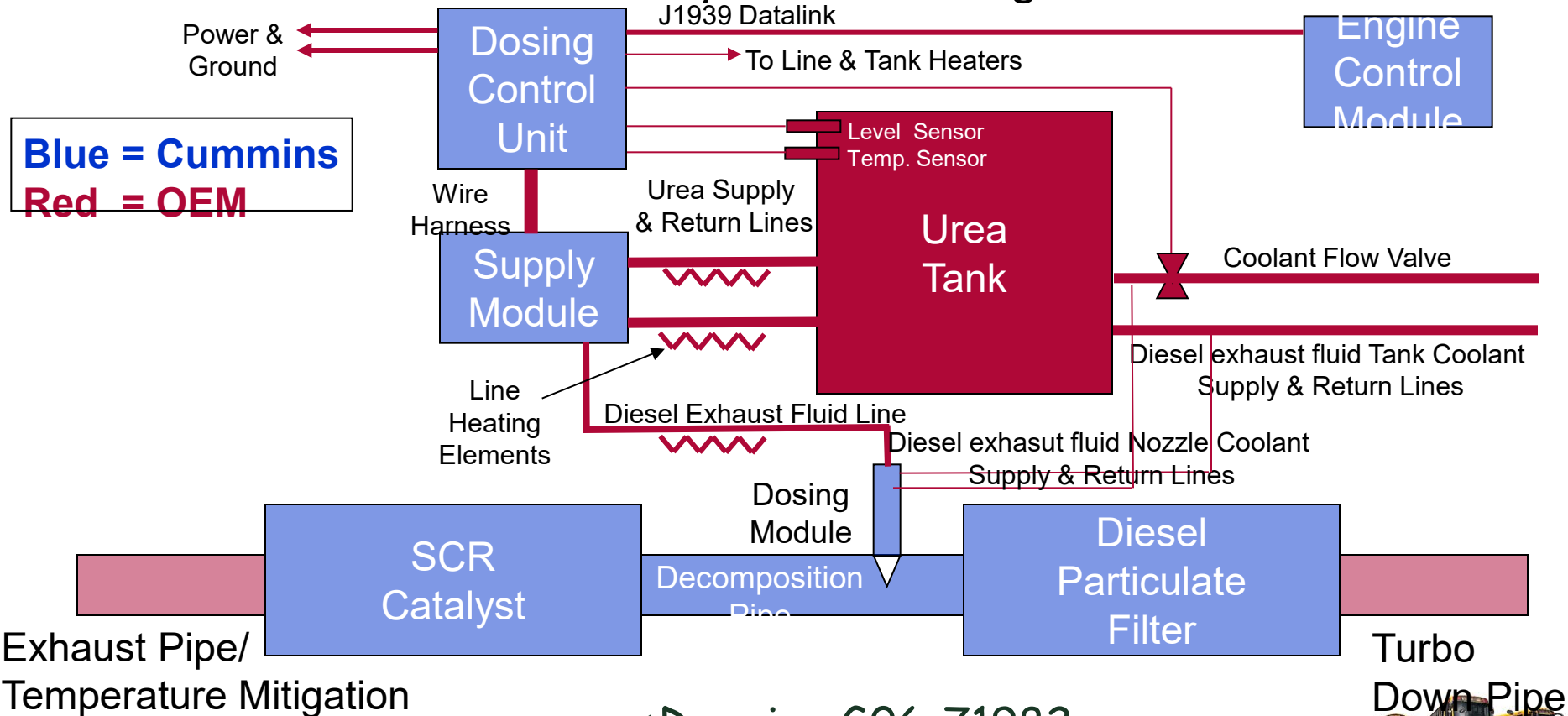

✓ Drawing G06-71982



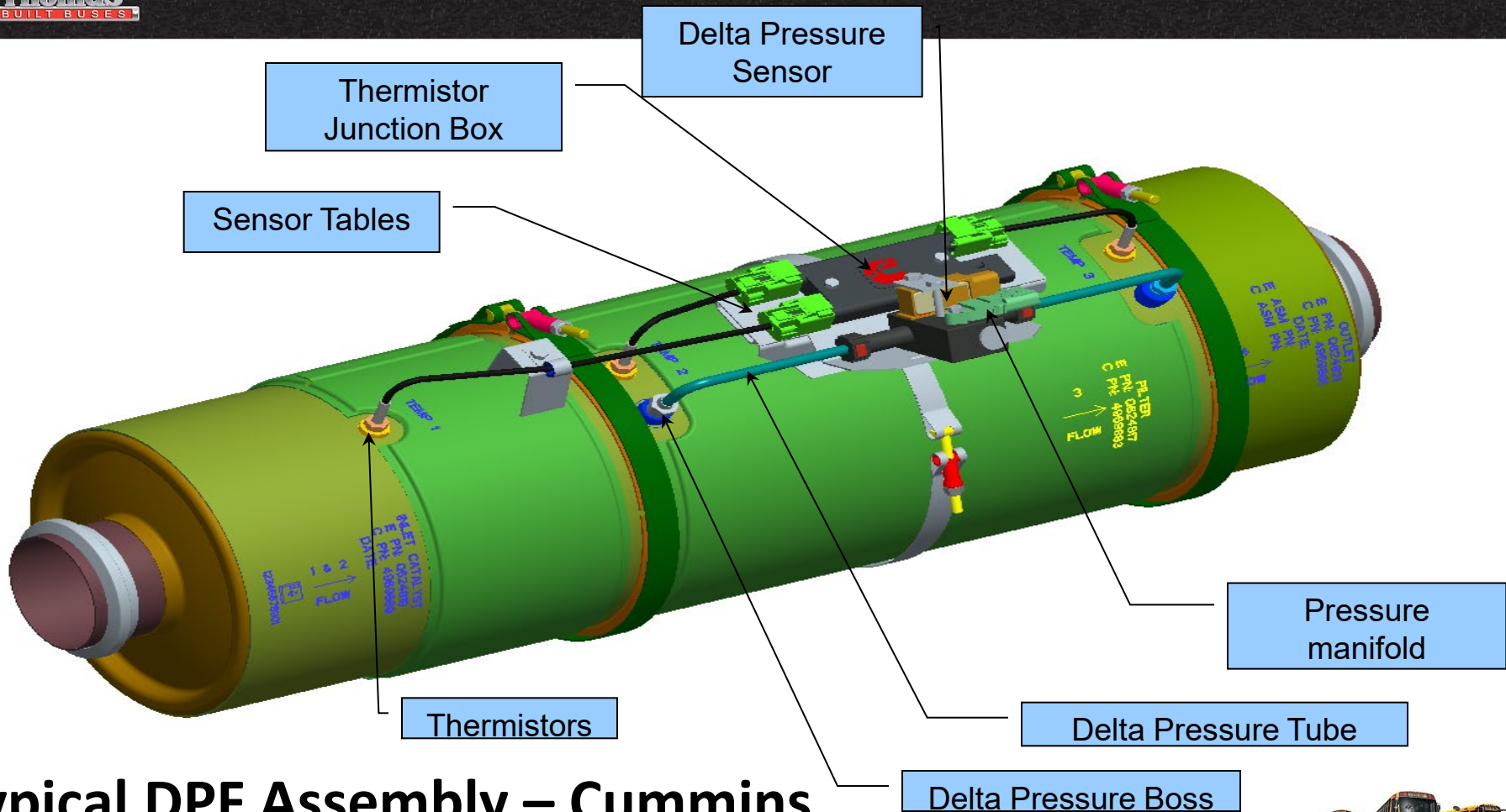

# Typical DPF Assembly – Cummins



# Decomposition Tube – Cummins

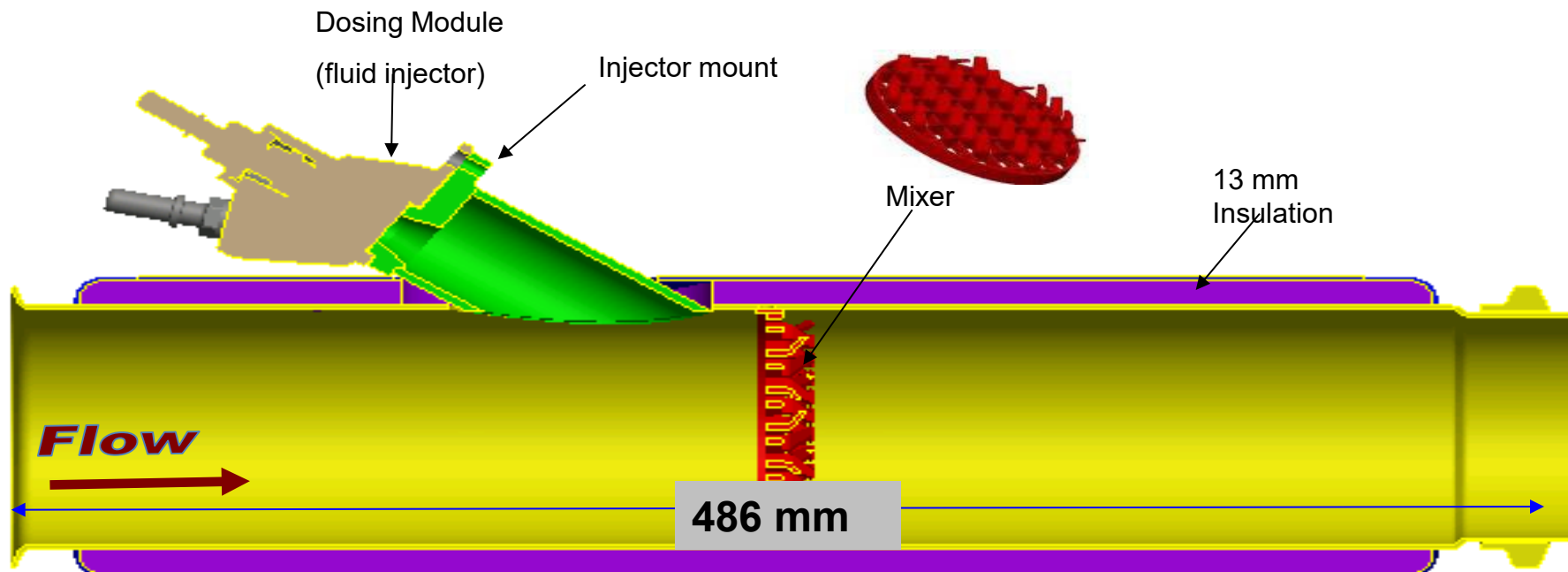

Exhaust flow carries the DEF to the SCR





Leaking at the injector port can be caused by crystal build up in the pipe.  
If seen remove pipe and clean out inside and replace gasket





# Typical Cummins SCR Assembly

Temperature sensors confirm the chemical change took place.

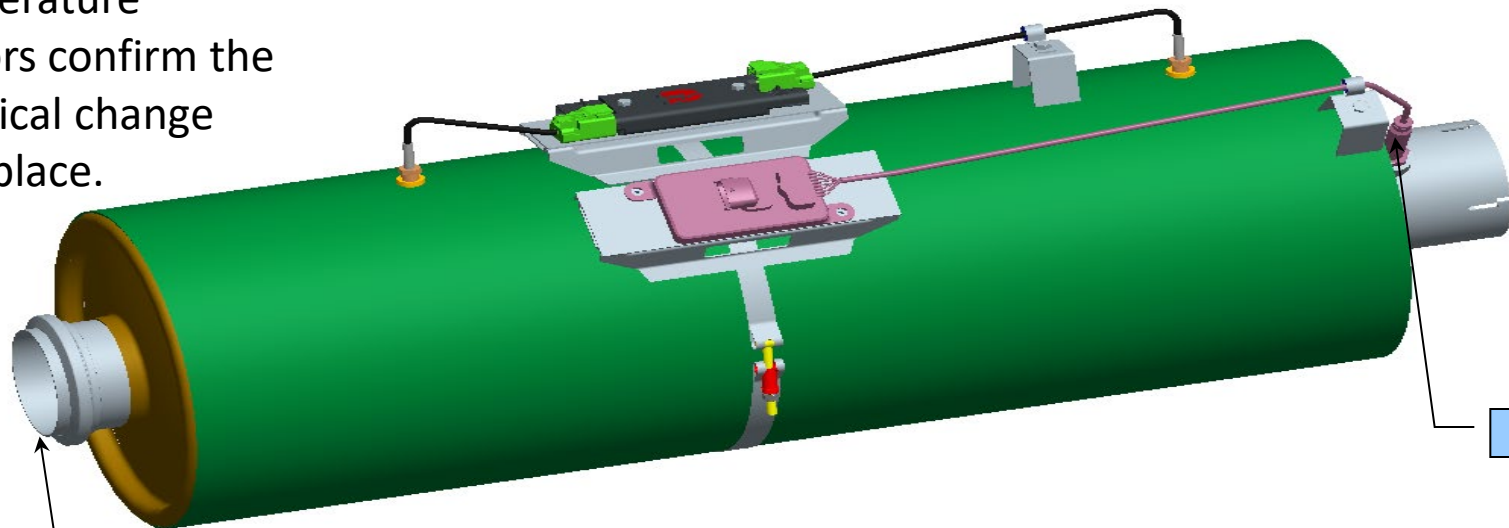

Inlet will be Flared  
Marmon

NOx Sensor



# Diesel Exhaust Fluid Dosing System – Cummins

Diesel Exhaust Fluid Supply Module is the pump and contains a strainer filter

Dosing Control Unit communicates with the engine to control the system

Dosing Module is located on the decomposition pipe between the DPF and the SCR

**Diesel Exhaust Fluid Supply Module**

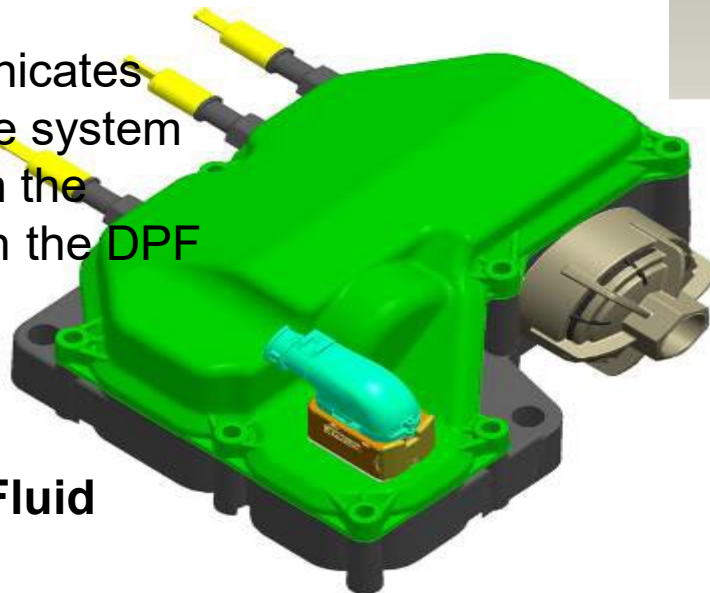

## Dosing Control Unit



2010 – 2013  
used.

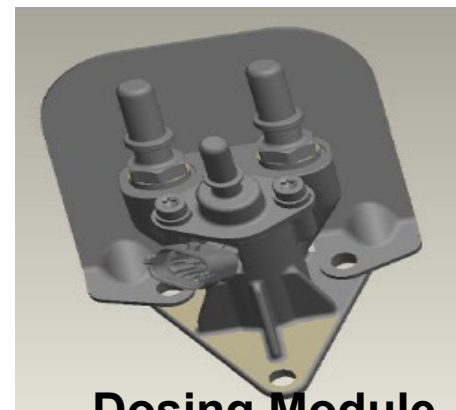

**Dosing Module**



# SCR Dosing Control Unit

- Communicates with the engine on the J1939 harness
- Controls the DEF supply pump
- Controls the Dosing Injector Unit
- Used on EPA2010 to EPA2013 engines.
- No longer used with EPA2013 (2014 buses)
- Brains of the system reside in the engine ECM now.

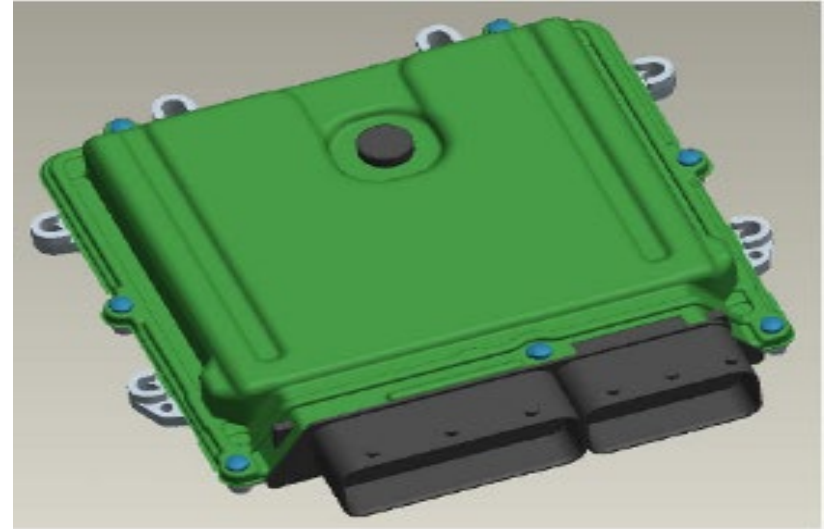

## Diesel Exhaust Fluid Pump

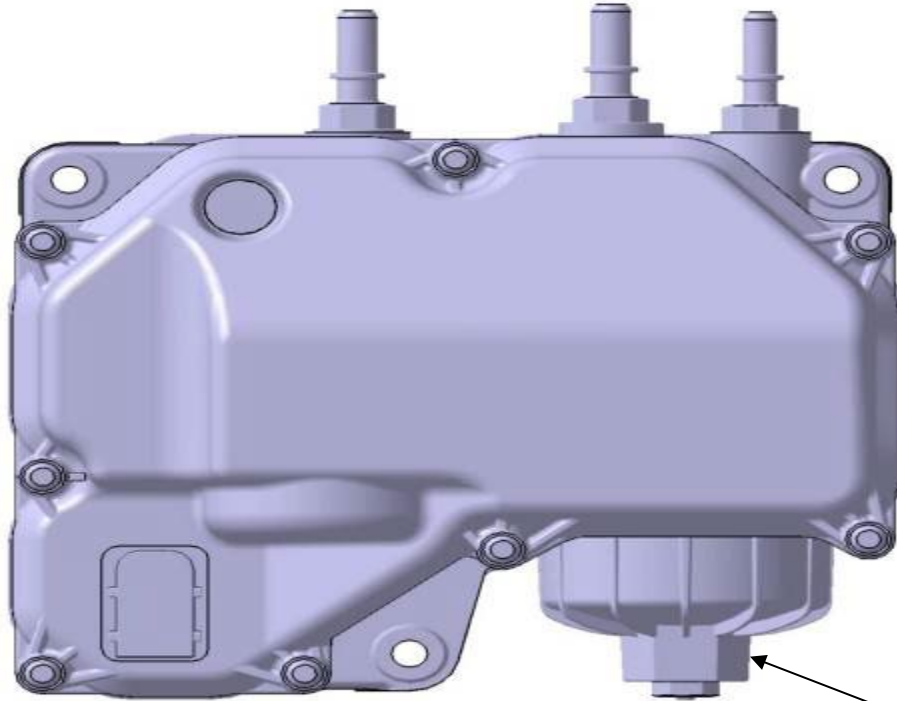

Recommend to change if wrong fluid is introduced or when changing DPF filter.

Removable Filter Element Requires Periodic Replacement  
2 yrs/224,000 mi



# DEF Fluid Lines

- Quick Connect Fittings
- Less than 3 Meter Length
- Lines are Heated
- Lines Will Not Burst When Contents are Frozen
- Heat is controlled by engine ECM based on temperature of the DEF fluid

Sample Lines

1/4" 90°  
elbow  
connector

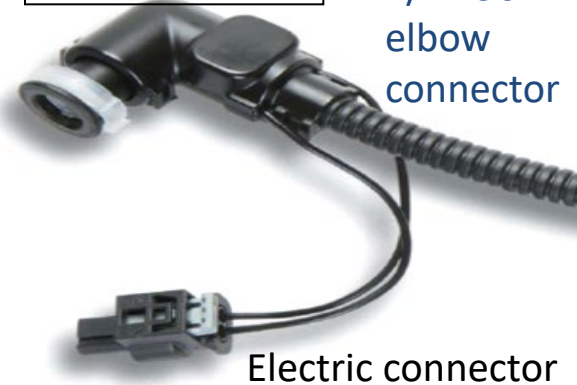

Electric connector



PA-tube with coiled heating wire



# Vehicle Range & DEF Tank Status –

% Full	Indicator Lamp
75% to 100%	4 green lights
50% to 75%	3 green lights
25 % to 50%	2 green lights
15% to 25%	1 green light
5% to 15%	1 yellow light & DEF lamp
0% to 5%	1 red light & DEF lamp
0%	1 red light flashing & DEF lamp

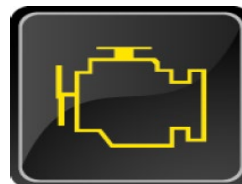

Malfunction Indicator Lamp

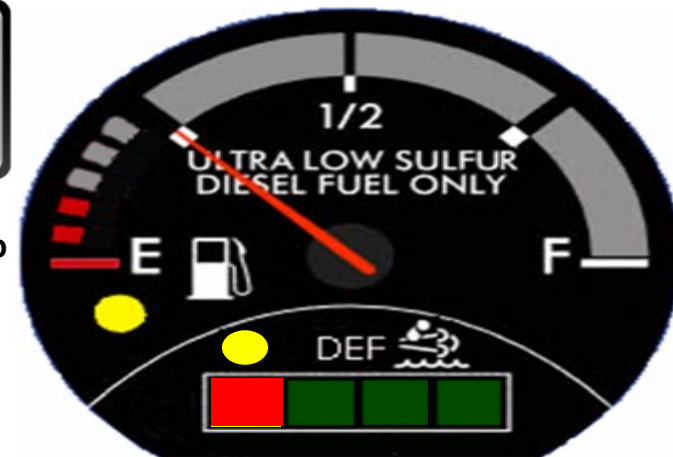

C2 gauge shown

Lights indicate a range not exact level

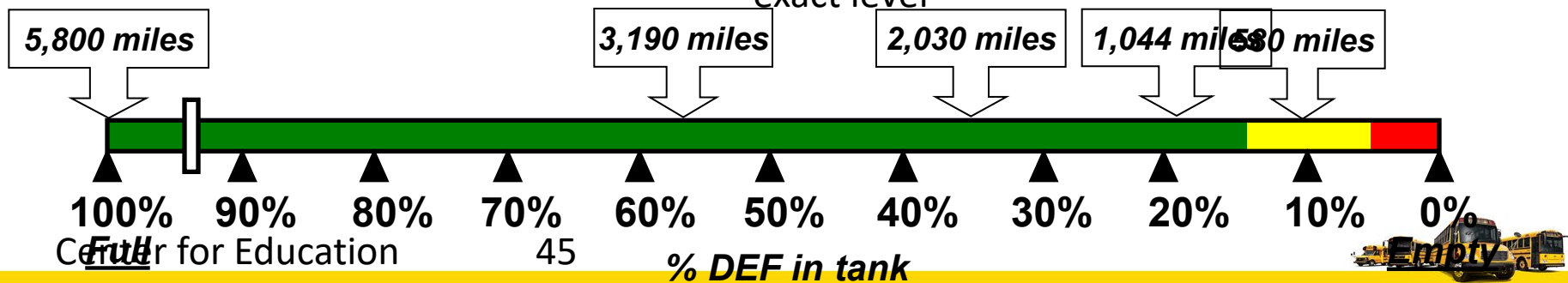

# DEF Sender

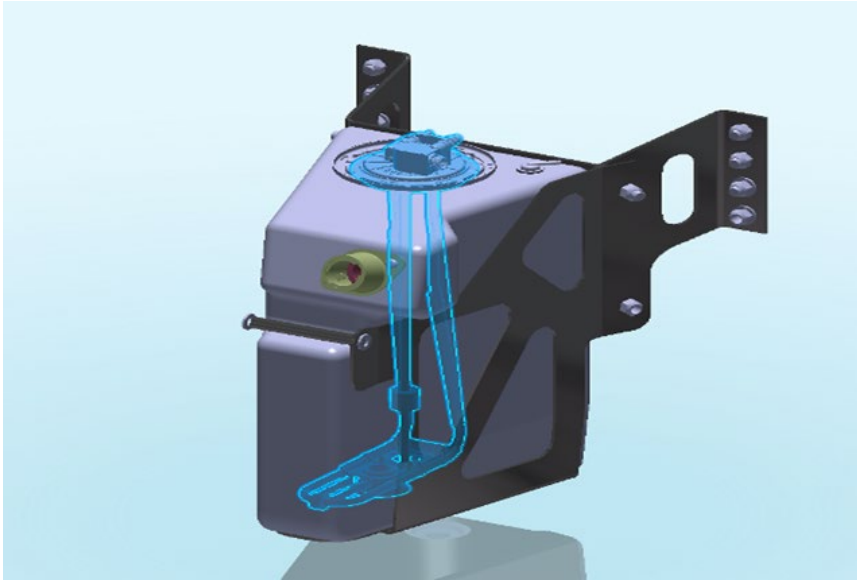

- DEF sender uses a float to read level
- Float sits on top of fluid
- When are contacts DEF and evaporation occurs you get white crystals forming
- Keeping the tank fluid level full often reduces stuck floats



# Oops Wrong Fluid

If wrong fluid is added but vehicle not started

- Drain the tank
- Flush tank with distilled water until clean
- If not able to clean then replace tank
- Replace the sending unit filter

If wrong fluid is added and vehicle is started.

- All same as if not started plus
- Clean or replace any items touched by the fluid
  - Lines
  - Pump
  - DEF Filter
  - Injector
  - SCR catalyst if needed



# What happens if the DEF runs out completely?

- The tank will run on empty before it de-rates until the key is switched off. The 5 mph inducement for low DEF starts only when the vehicle is turned back on with a previously empty tank. There is no situation where a bus will de-rate **to 5mph** due to DEF level or quality as it is being driven.
- The engine will de-rate torque by 12 to 17% when the check engine light comes on at the 2.5% DEF tank fill level.
- Here is a break down of the stage-by-stage process:
  - >10% full - no lamp or notification
  - 10% full - DEF lamp turns on, no inducement [stage 1]
  - 5% full - DEF lamp flashes, no inducement [stage 2]
  - 2.5% full - DEF lamp flashes, amber check engine lamp turns on, engine de-rates by 12- 17% torque [stage 3]
  - empty, after engine has been shut down - DEF lamp flashes, red check engine light turns on, vehicle limited to 5 mph. [stage 4]



# 2016 Product Changes

- Particulate Matter (PM) Sensor
  - Added for ISB6.7 in 2016

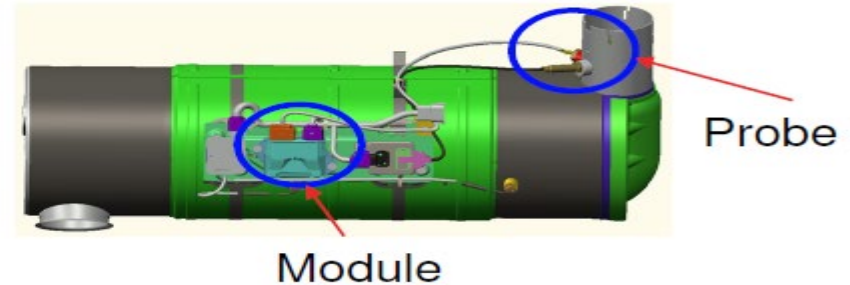
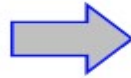
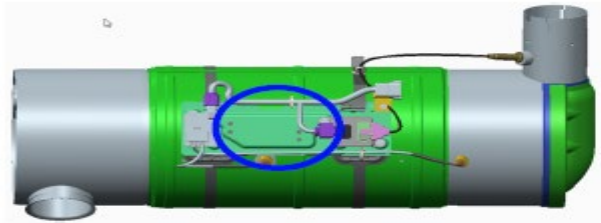

# 2016 Product Changes

- Diesel Exhaust Fluid (DEF) Quality Sensor
  - Added for all diesel products

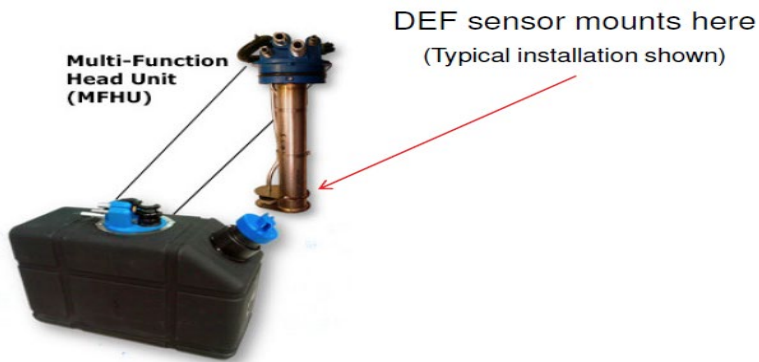

## Key Factors for MDEG Success in NAFTA



- The MDEG platform will be primarily focused on vocational and short haul markets.
  - Success in these markets will depend on reliability, fuel economy and improved aftertreatment performance in lower duty cycle applications.
- Three primary development strategies focused on ATS performance:
  - Variable Cam Phasing
  - Multiple Injection Event Control
  - Wastegate & EGR control



# Variable Camshaft Phaser: Mechanical Components

- 1- Cover Plate
- 2- Control Plunger
- 3- Return Check Valve
- 4- Valve Housing
- 5- Rotor
- 6- Adjustment Housing
- 7- Exhaust Cam Gear
- 8- Timing Plate
- 9- Locking Pin & Spring
- 10- Circuit Oil Feed

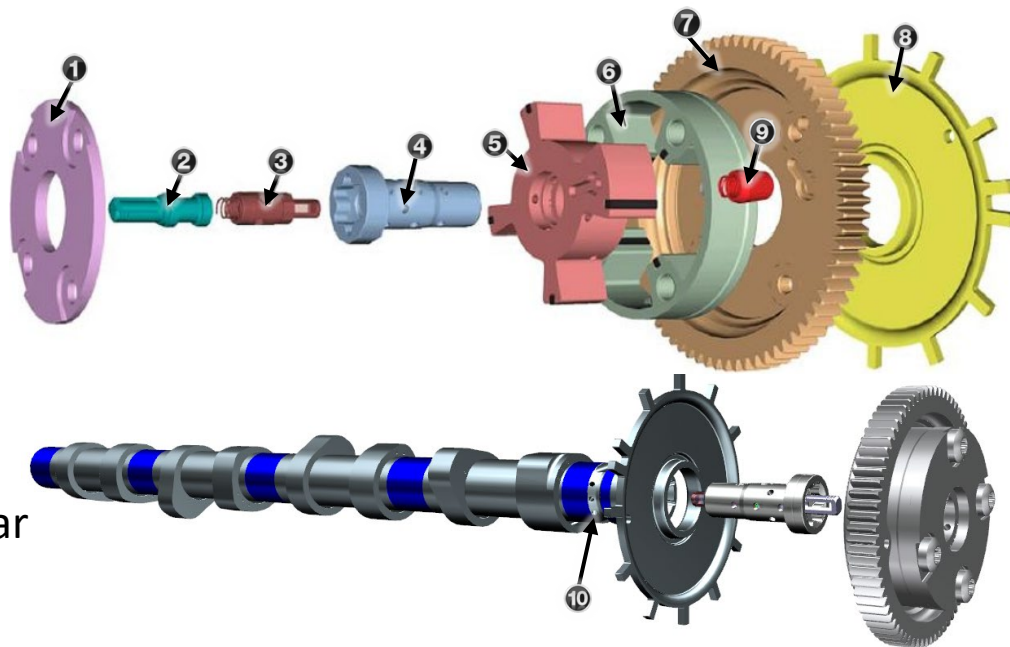

# Variable Camshaft Phaser

- 1 Adjustment Housing
- 2 Drive Gear
- 3 Pulse Ring
- 4 Check Valve
- 5 Exhaust Camshaft
- 6 Compression Spring
- 7 Valve Housing (of control valve)
- 8 Rotor
- 9 Control Plunger
- 10 Pressure Plunger
- 11 Chamber B
- 12 Chamber A
- 13 Supply Chamber
- 14 Bushing
- 15 Bore to Chamber B
- 16 Bore to Chamber A

A = Oil under operating pressure

B = Oil unpressurized

X = Rotation direction

Y = Contact position

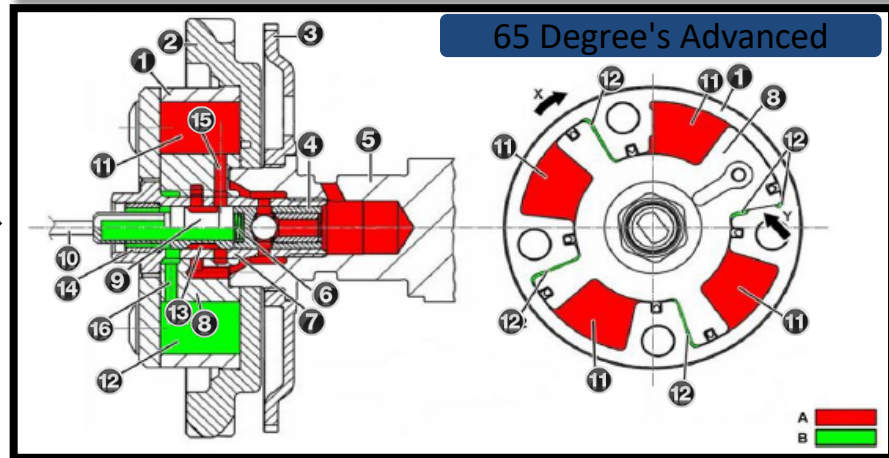
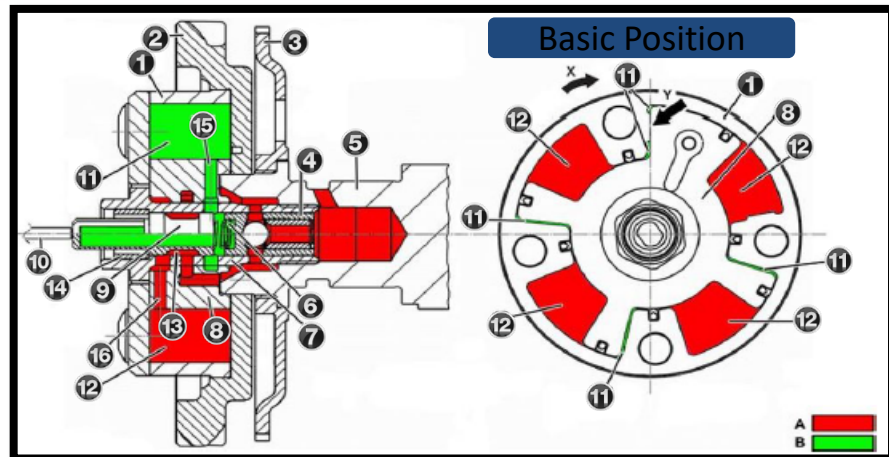
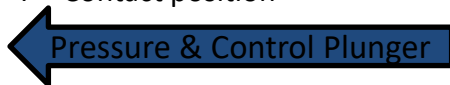

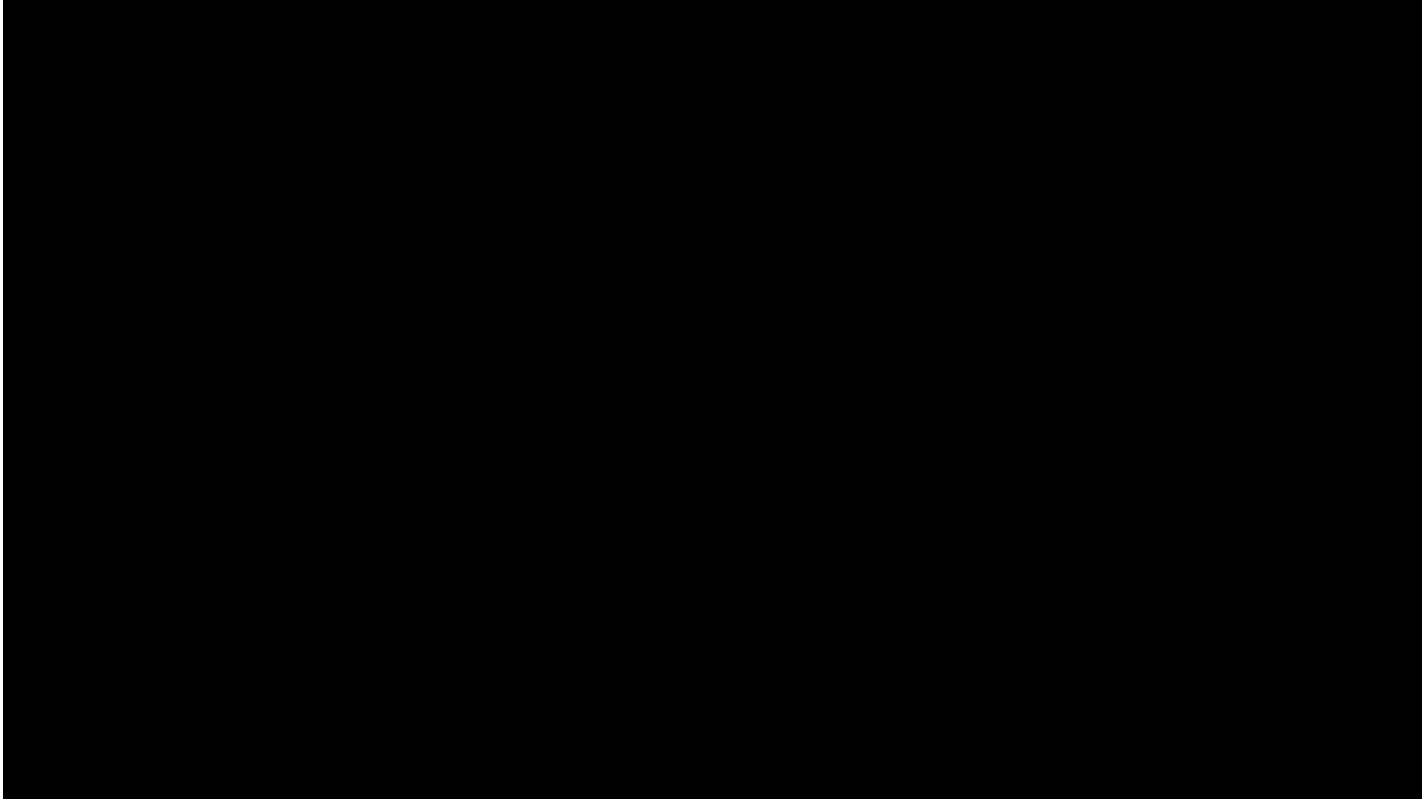

VCP Will Be Commanded To 25/35/45/65 Then To 0 Dergrees  
 Listen To The Different Sound Pitch Frequencies  
 As The Engine Transitions Through The VCP Set Points

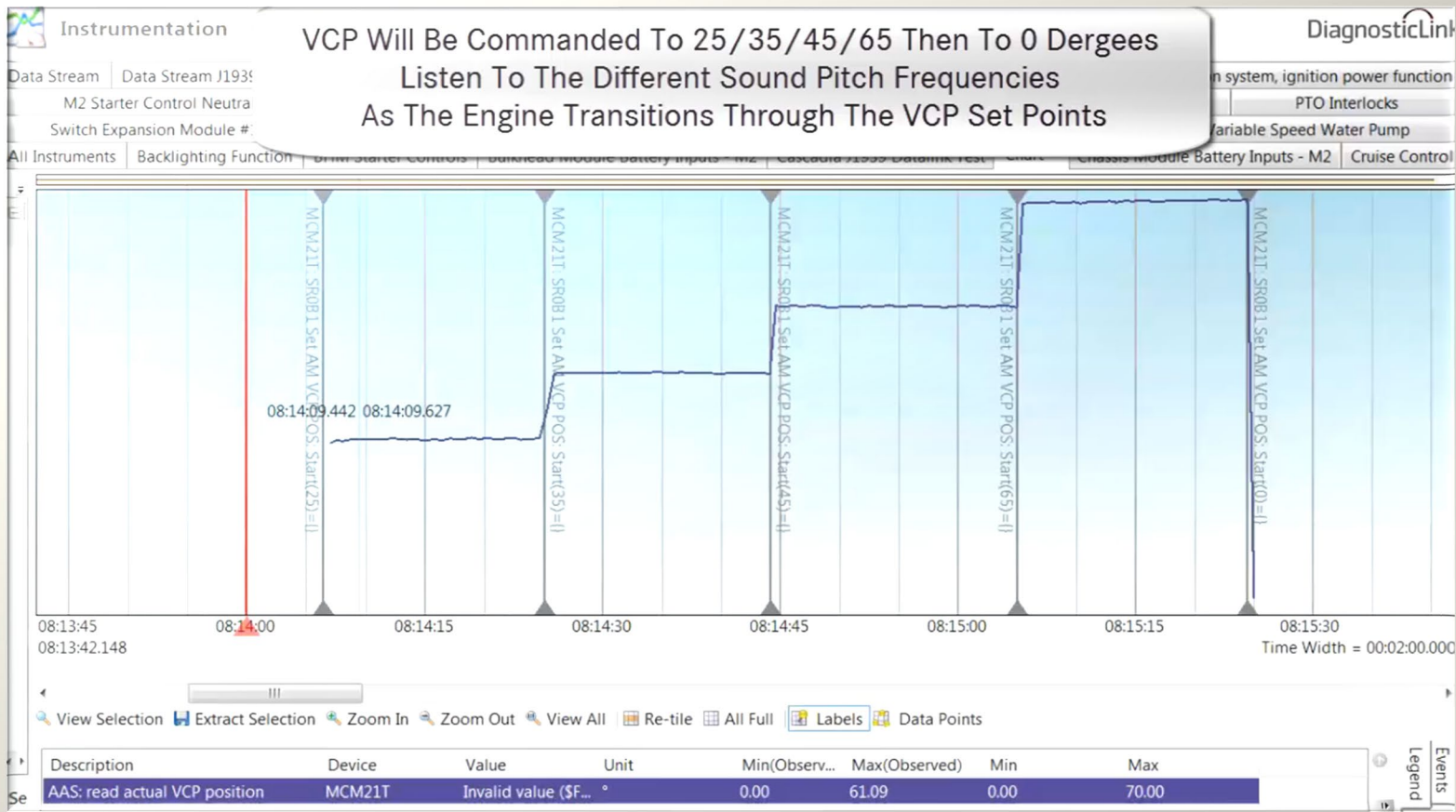

# SERVICE TRAINING ACADEMY

DAIMLER TRUCKS NORTH AMERICA



DD8 Single Stage Turbo ATS  
DD8 Dual Stage Turbo ATS  
2Box Horizontal ATS  
There Is No Narration To This Module



# Aftertreatment Systems Overview

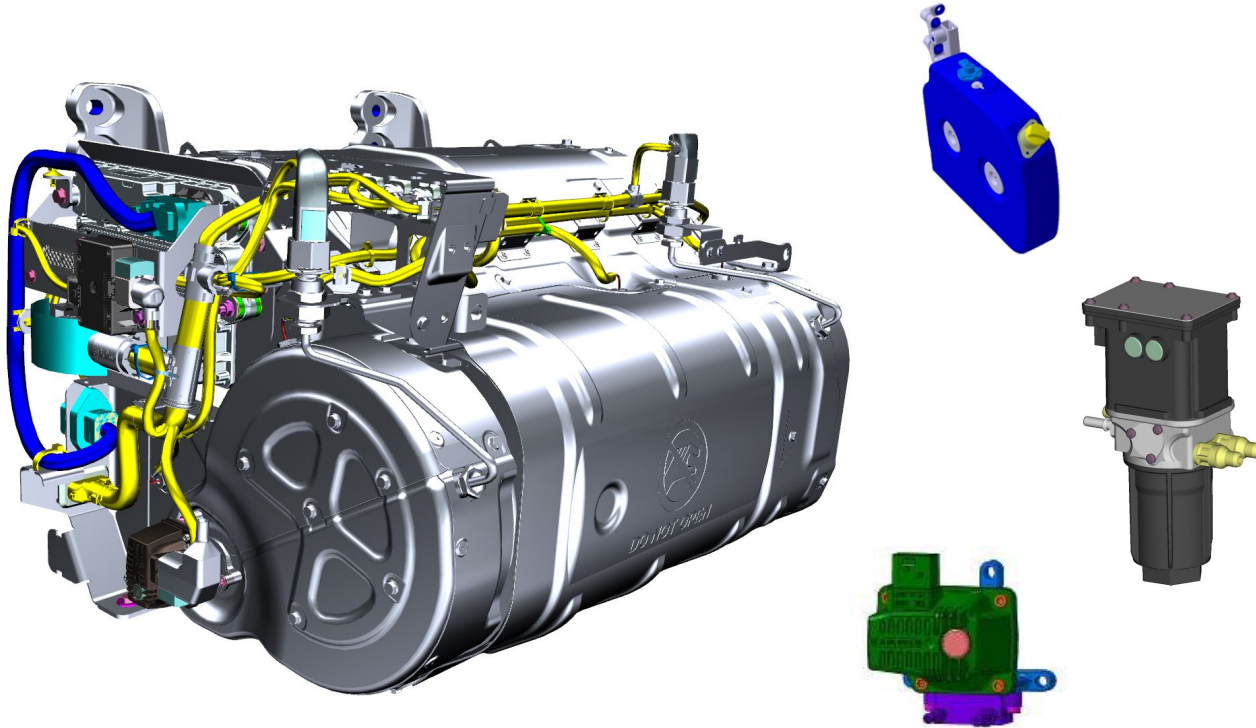

# 1BOX Configuration Front Side

- 1 DOC Inlet Pressure
- 2 DOC Inlet Temperature
- 3 DOC Outlet Temperature
- 4 DPF Outlet Pressure

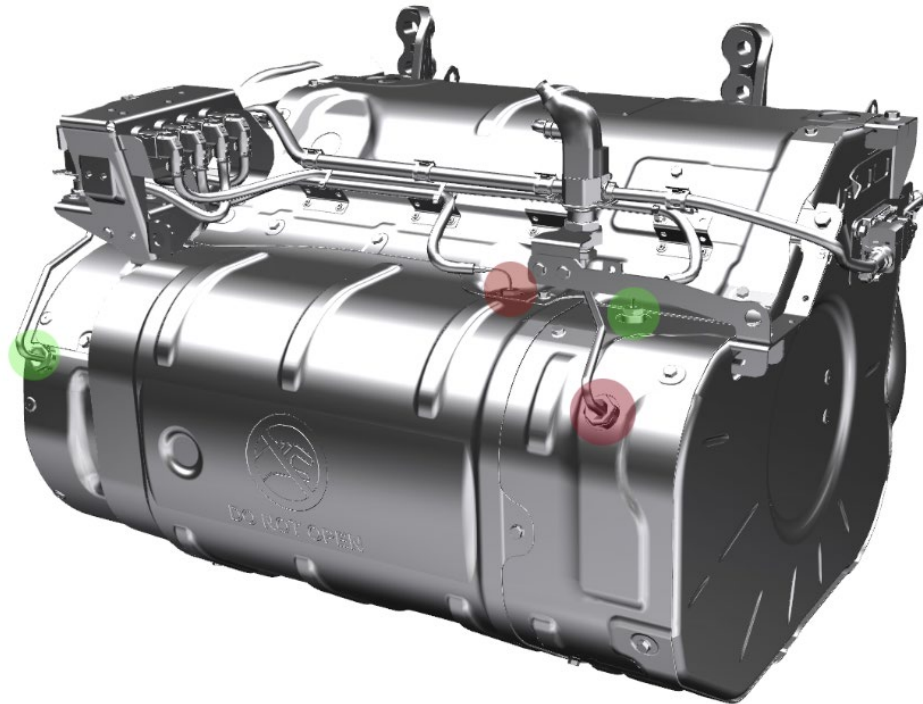

# 1BOX Configuration Rear Side

- 1 Vehicle Interface
- 2 DEF Tank/Pump Interface
- 3 SCR Outlet Temperature
- 4 Soot Sensor
- 5 NOx Outlet Sensor
- 6 NOx Inlet Sensor

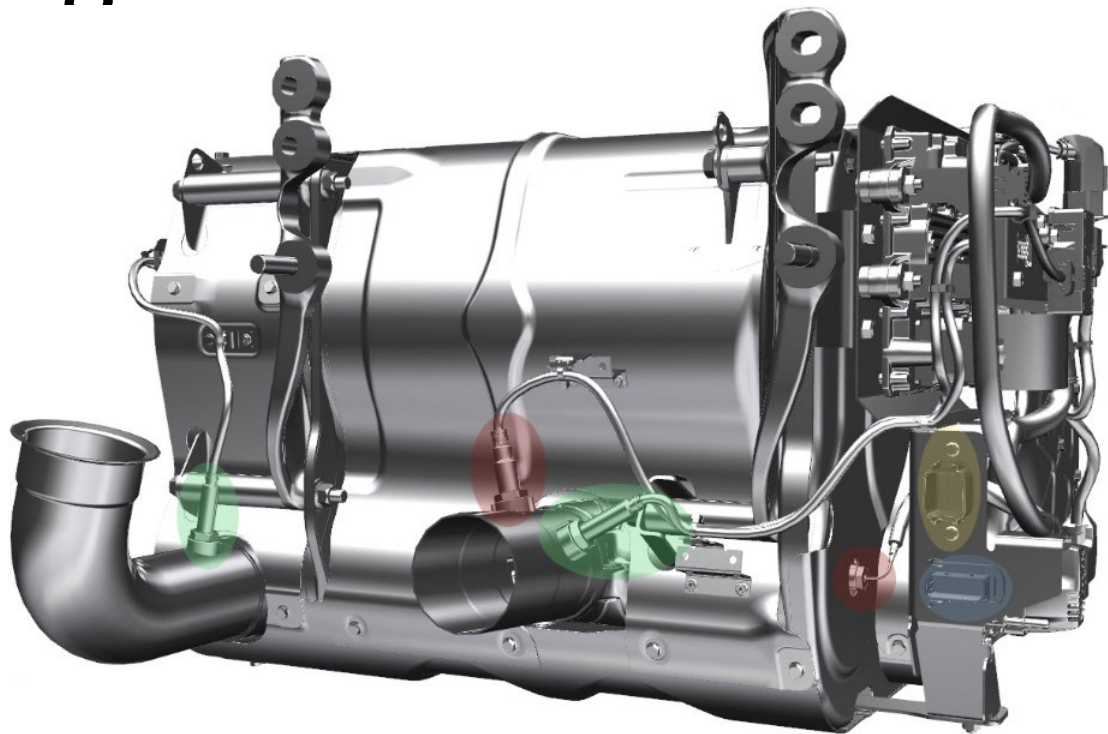

# MDEG Airless Dosing System

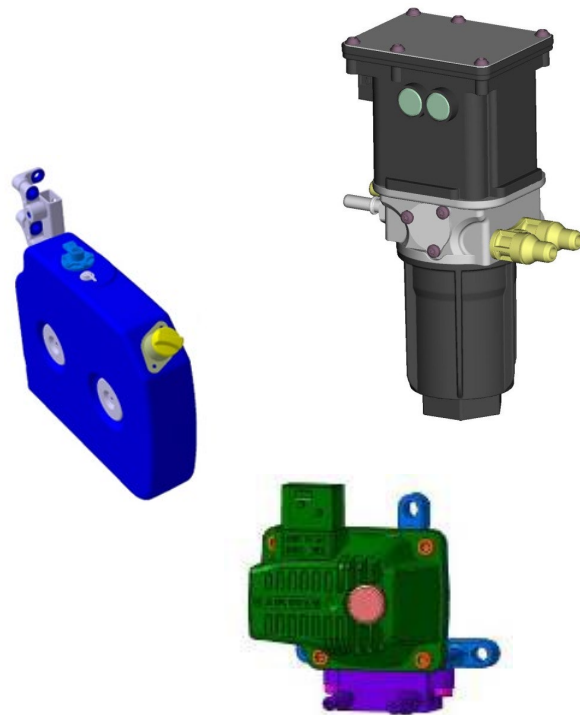
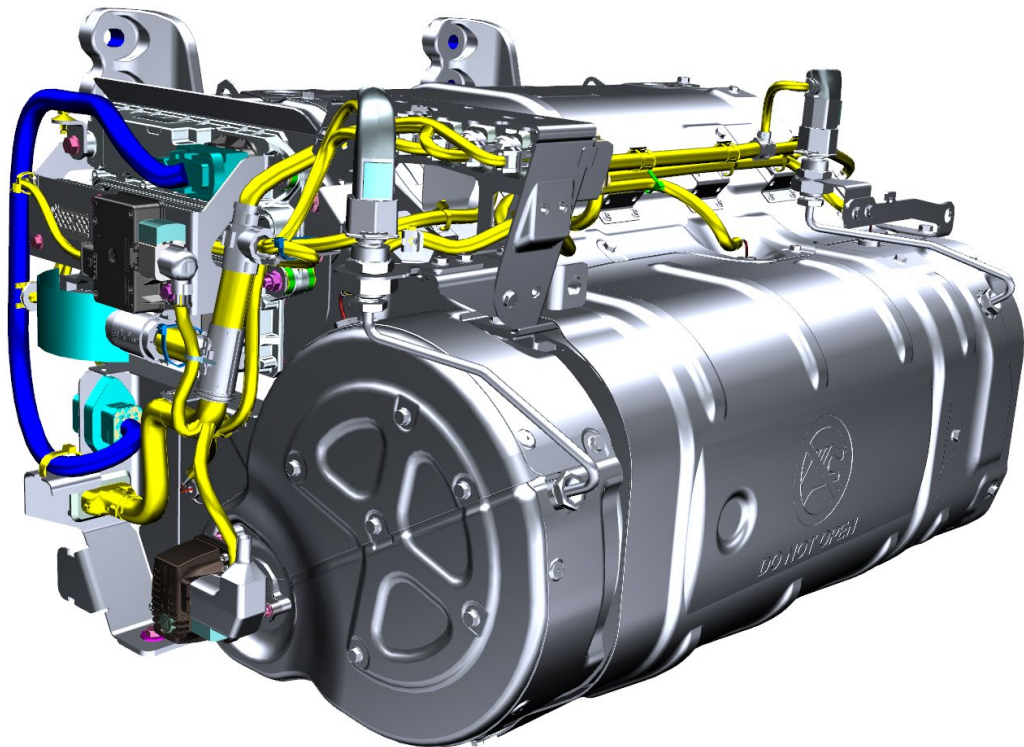

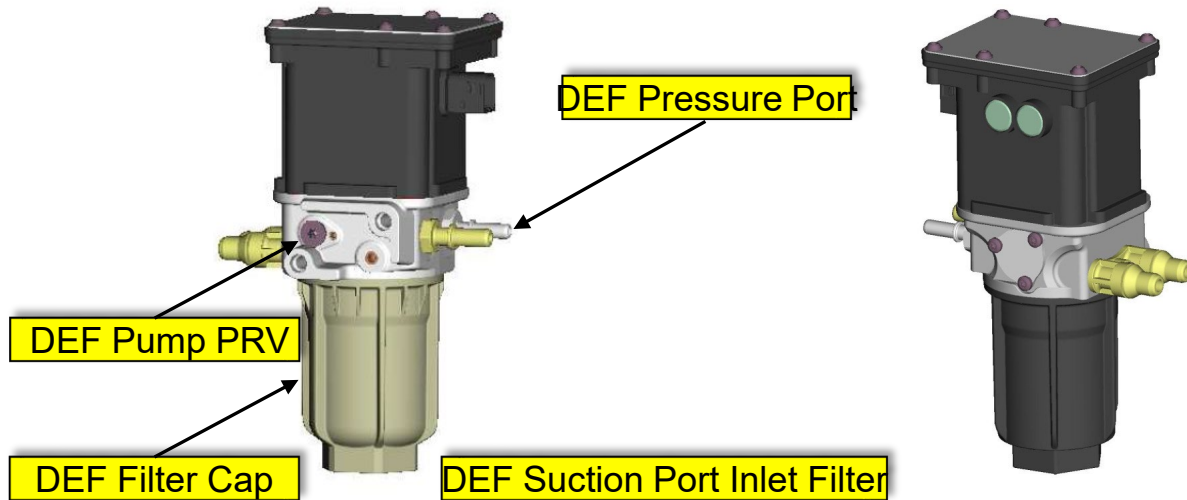

# MDEG Airless Dosing System



- The DEF PRV opens at 188psi
- The DEF filter is 100 microns
- Pump operation, to prime the system the pump runs at 3,500rpm, 1,100rpm to maintain 145psi, Then 2,500rpm while the system is dosing to maintain the 145psi. Defaults to 65535rpm when not functioning, limp home mode 1200rpm
- The filter cap is not DEF friendly
- Some pumps were tested with DEF at the factory, so if a pump will not create pressure out of the Box you will need to blow 90psi in the inlet port for 5sec. If the pump was not tested with DEF There will be two blue dots on the body.

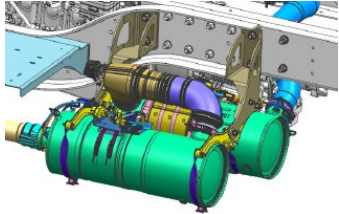
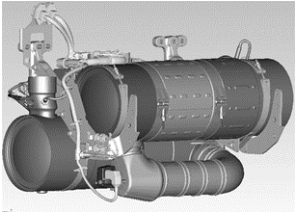

# DD5/DD8 Technical Features and Benefits

Feature		Benefits
 <p data-bbox="401 587 683 609">Side-By-Side Aftertreatment</p>		<ul style="list-style-type: none"> <li>▪ Insulated piping (between turbo / ATS and between DPF / SCR) to maintain exhaust heat and improve regeneration performance</li> <li>▪ Common DEF doser and DEF pump with HDEP</li> <li>▪ Common ATS sensors with HDEP (NOx, Soot, temperature and pressure)</li> <li>▪ Utilizing common hardware with HDEP leverages 10+ years of ATS experience resulting in more reliable performance and better serviceability</li> <li>▪ Serviceable DOC / DPF / SCR</li> </ul>
 <p data-bbox="436 871 651 893">Inline Aftertreatment</p>		



# 2017 Changes to Aftertreatment

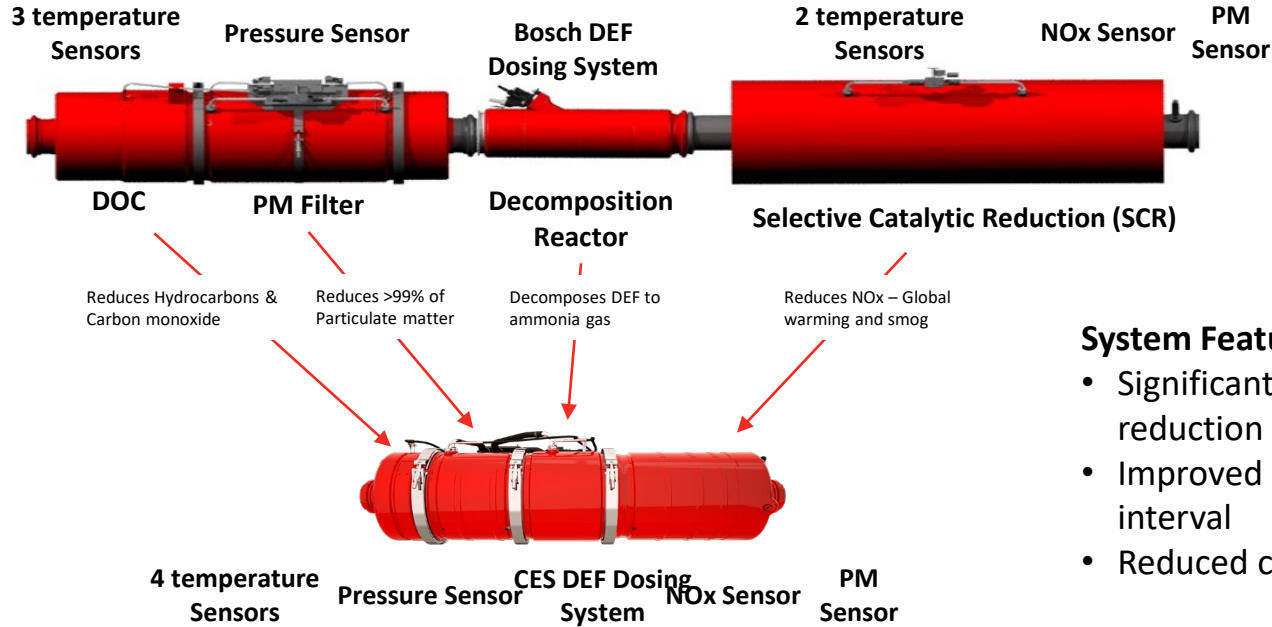

## System Features:

- Significant size and weight reduction
- Improved ash holding / service interval
- Reduced complexity



# Typical Cummins SCR Assembly

Temperature sensors confirm the chemical change took place.

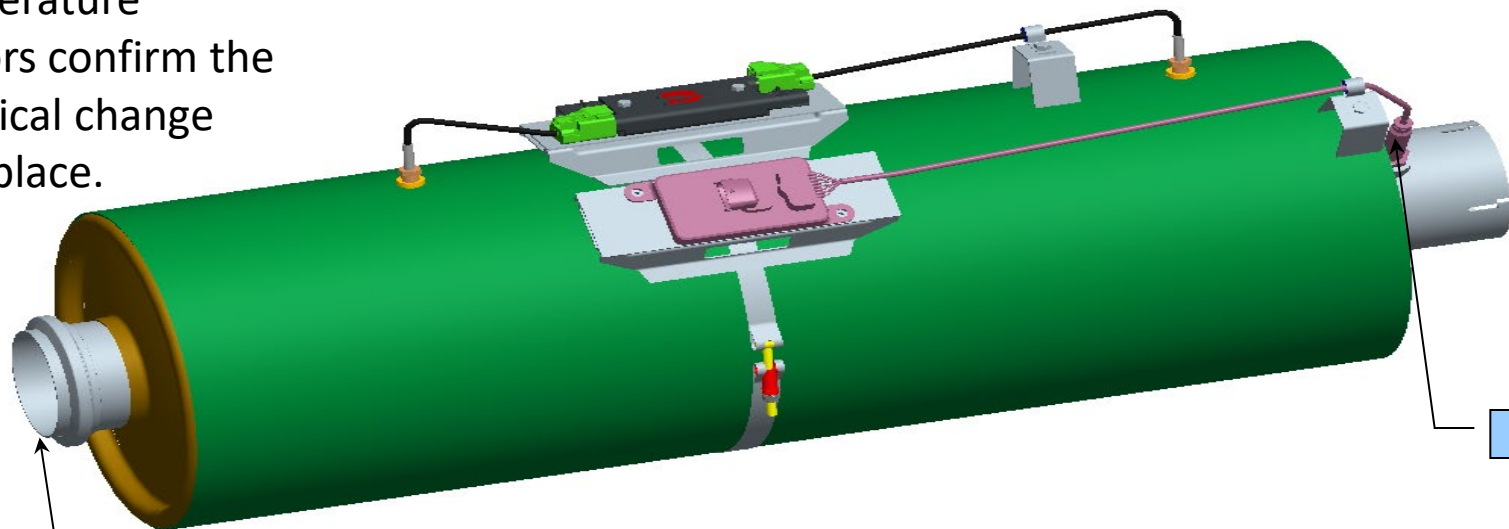

Inlet will be Flared  
Marmon

NOx Sensor



# 2017 Single Module Aftertreatment

- Customer voice-driven design for full range of engines
- System features:
  - Up to **33%** reduction in size
  - Up to **15%** reduction in weight
  - Enhanced efficiency

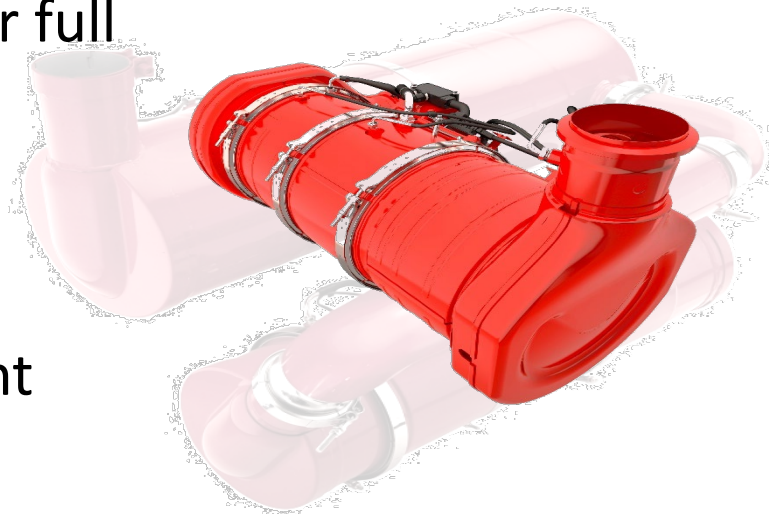

# 2017 Changes to Aftertreatment

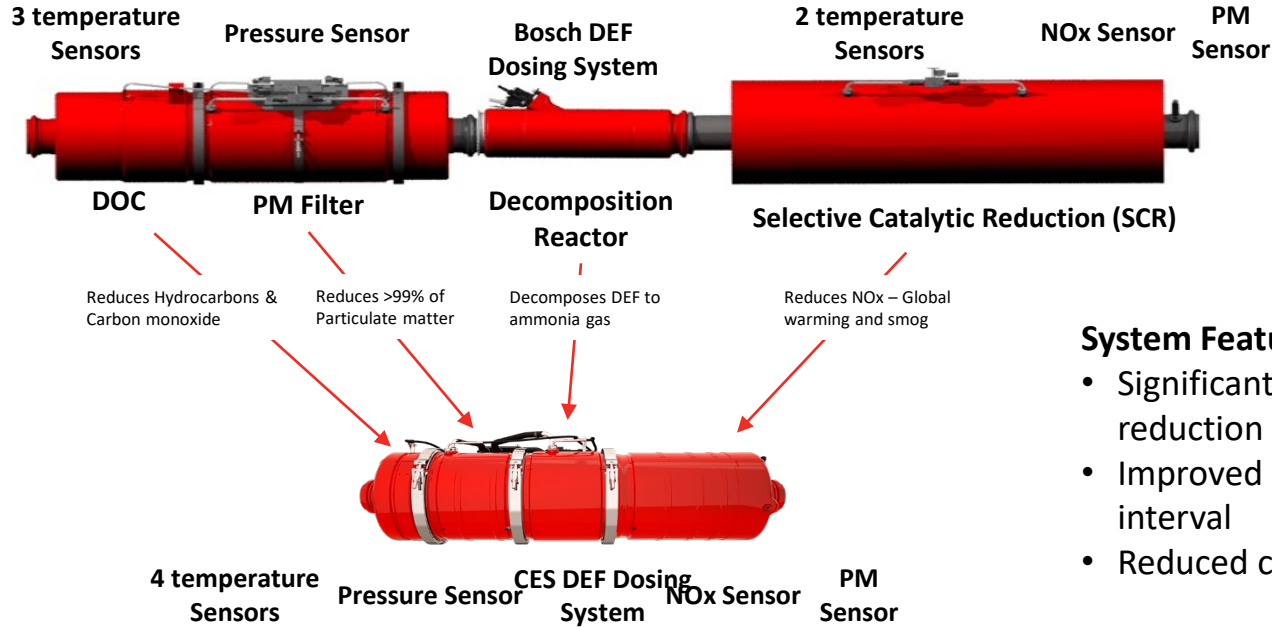

## System Features:

- Significant size and weight reduction
- Improved ash holding / service interval
- Reduced complexity



# Packaged For Performance

- Simpler packaging allows for:
  - Fewer variations across the system, offering system integration benefits to OEM customers
  - More robust and reliable system for the end-user
- Smaller size also enables better heat management and improved fuel economy



# Simple & Optimized DEF Dosing

- The UL2 system does not require engine coolant lines to and from the diesel exhaust fluid (DEF) injector, reducing installation complexity
- The system provides more efficient atomization and minimizes deposit formation
- Higher NOx reduction efficiency enables fewer DPF regeneration events and optimizing DEF consumption throughout the system



# A Visual Guide to Emissions

<b>2007</b> NOx: 1.5 g PM: .01 g	<b>2010</b> NOx: .20 g PM: .01 g	<b>2017 B6.7</b> NOx: 0.20 g PM: .001 g	<b>2021 B6.7</b> NOx: .20 g PM: .001 g CO2 limits	<b>2024 B6.7</b> NOx: .20 g PM: .001 g CO2 limits CO2 GEM veh. Limits	<b>2027 B6.7</b> NOx: .035 g PM: .001 g CO2 limits CO2 GEM veh. Limits
--	--	---	--	--	---

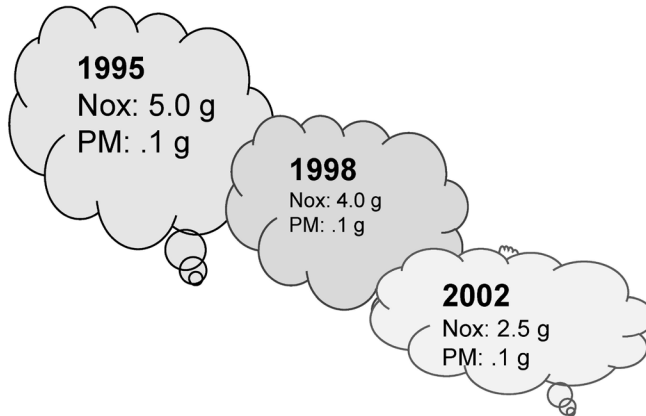

2017 FEDERAL EMISSIONS STANDARDS		Nitrogen Oxides (Acid Rain)	Particulate Matter (Carcinogen)	Carbon Monoxide (Greenhouse Gas)	Nonmethane Hydrocarbon (Smog)
		grams per brake horsepower per hour			
		0.20	0.01	15.5	0.14
		Certified Levels			
DIESEL	2018 Cummins B6.7	0.15	0.001	0.04	0.03
	2018 Detroit DD5	0.05	0.000	0.4	0.000
CNG	2018 Cummins B6.7N	0.08	0.000	3.00	0.01
PROPANE	2018 Roush V10	0.01	0.002	5.0	0.05
	2017 8.0L V8	0.16	0.003	5.6	0.09
GAS	2018 Ford V10	0.08	0.002	12.9	0.08
	2018 PSI 8.8L	0.04	0.002	3.7	0.08

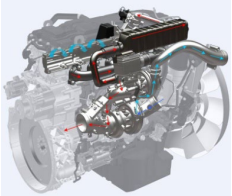
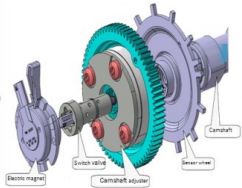

# DD5/DD8 Technical Features and Benefits

Feature	Benefits
 <p data-bbox="369 500 674 525">Charge Air and Exhaust System</p>	<ul data-bbox="765 241 1528 568" style="list-style-type: none"> <li>▪ Single-flow exhaust system (100% exhaust flow through primary turbo) with either single or dual-stage turbo charging with electrically controlled wastegate</li> <li>▪ Simple fixed geometry single or dual-stage turbocharger for performance, efficiency, and reliability</li> <li>▪ Hydrocarbon-doser for DPF regeneration common with HDEP platform having 10 years of experience and refinement (additional support for regeneration by camshaft phase adjustment)</li> <li>▪ Efficient regeneration of the diesel particulate filter to keep you running uninterrupted</li> </ul>
 <p data-bbox="459 852 585 877">Cam Phasing</p>	<ul data-bbox="765 594 1518 809" style="list-style-type: none"> <li>▪ Advanced variable cam phasing technology provides the MDEG with improved aftertreatment system performance (variable, early opening of exhaust valves increases temperature of exhaust at all operating conditions, including idle) for effective DPF regeneration in all conditions</li> <li>▪ Variable Cam Phasing also helps reduce or eliminate hydrocarbon accumulation by maintaining elevated exhaust temperatures, even under low load conditions</li> </ul>

Leveraging the expertise of our Global Powertrain engineering and development team, the MDEG is unprecedented when it comes to innovation, performance, and reliability.

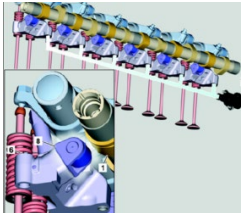
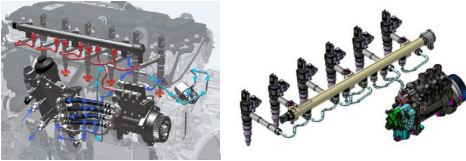

# DD5/DD8 Technical Features and Benefits

Feature	Benefits
 <p data-bbox="401 481 710 503">Integrated Engine Brake Option</p>	<ul data-bbox="819 248 1591 463" style="list-style-type: none"> <li>▪ Impressive optional integrated two-stage engine brake</li> <li>▪ Developed in-house with very compact cylinder head packaging</li> <li>▪ Activation of the wastegate and EGR valve provide additional power to the engine braking</li> <li>▪ DD5 has up to 240 hp of braking</li> <li>▪ DD8 has up to 420 hp of braking</li> </ul>
 <p data-bbox="452 718 660 740">Fuel injection system</p>	<ul data-bbox="819 530 1591 805" style="list-style-type: none"> <li>▪ Advanced high pressure common rail fuel system</li> <li>▪ Non-amplified injectors with 10-hole nozzle allow for precise combustion control</li> <li>▪ Up to 5 separate injection events per combustion cycle for improved efficiency and emissions control. Post injection events are used to elevate exhaust temperatures quicker and maintain elevated temperatures longer.</li> <li>▪ Oil lubricated high-pressure pump for durability, performance, and noise optimization</li> </ul>

From its integrated engine brake, to its reliable DDEC controls, to the advanced fuel injection system, this medium duty engine is built for your bottom line. As a pioneer in electronic engine control, Detroit has continuously refined and improved this technology. Both the DD5 and DD8 benefit from over a quarter century of electronic brainpower. The DD5 & DD8 will utilize the same Detroit electronic tools as used with heavy duty platform. No additional diagnostic equipment is required!



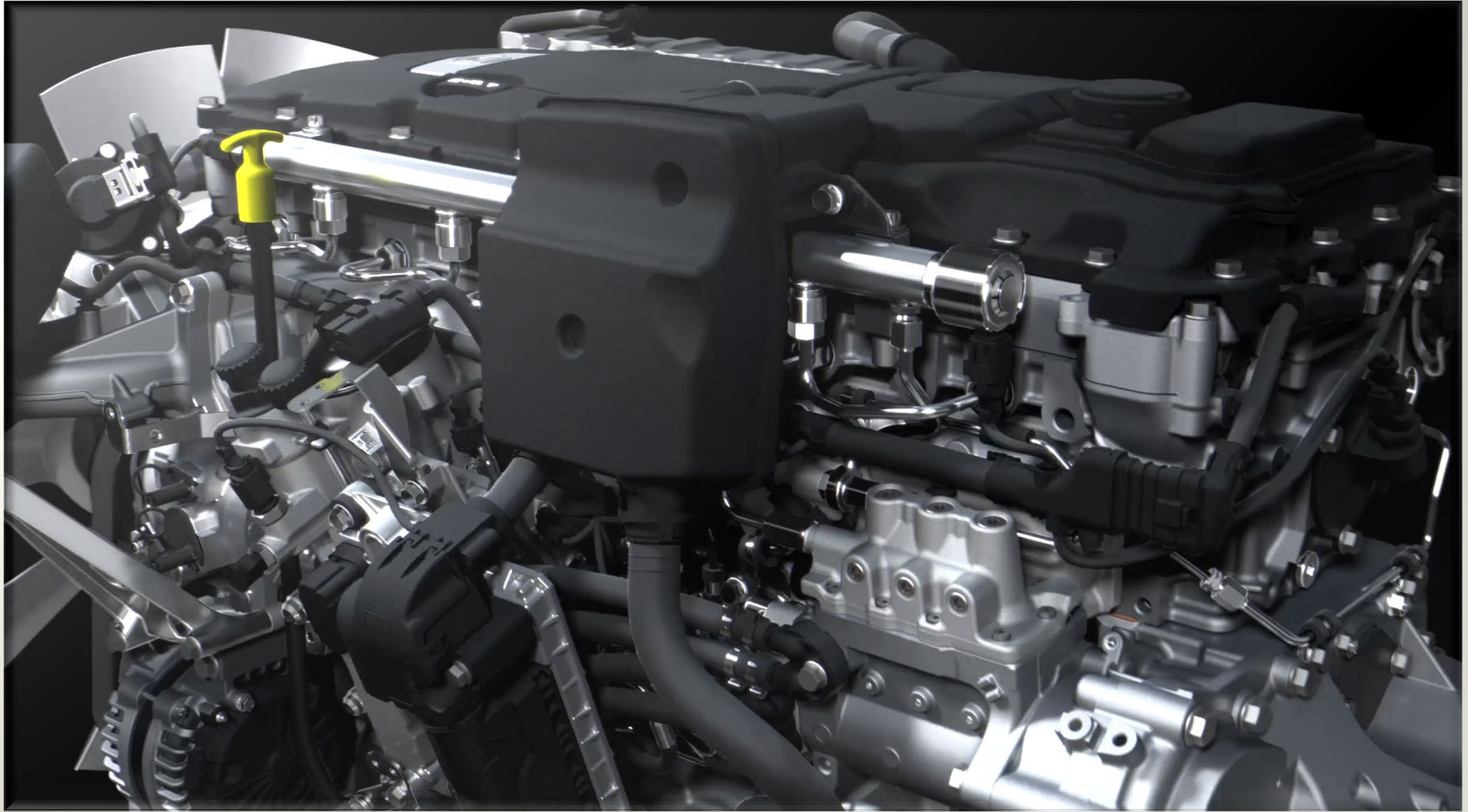

# DAIMLER

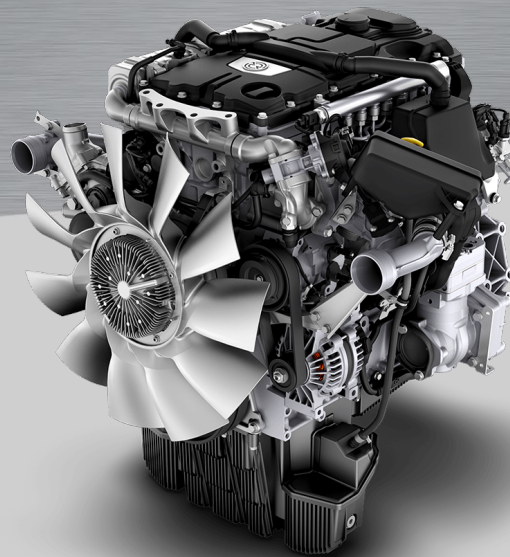
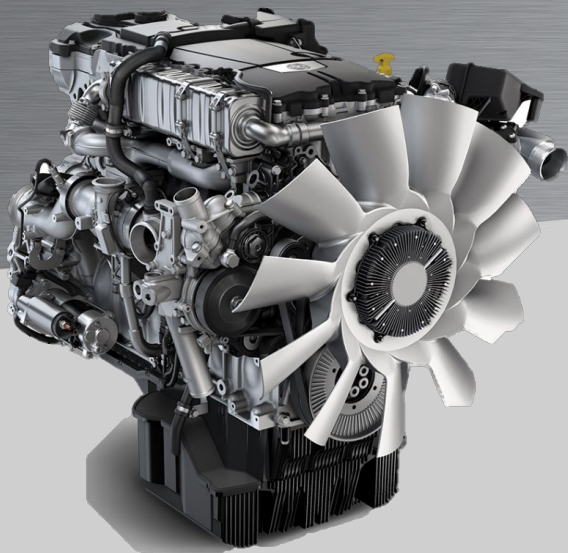

Thank you!

# B6.7™

## Octane Key Product Features

### Base Engine

- 6.7L Displacement
- 107 mm Bore x 124 mm Stroke
- 4 Head Bolt Gray Iron Block
- 4 Valve Aluminum Cylinder Head
- Dual Overhead Camshaft Valve Train
- Type II Roller Finger Follower Design

### Air Handling System

- Dual Independent Cam Phasing
- Wastegate Turbocharger with Command WG Actuator
- Compressor By-pass Valve - Routes compressor out flow/pressure back to the compressor inlet to mitigate surge
- Non-EGR System
- Naturally aspirated air compressor – OEM supplied plumbing
- Positive Crank Case Ventilation
- Compression Release Exhaust Brake

### Vehicle Integration

- System Weight Improved Over B6.7 Diesel
- Customer Interfaces Similar to B6.7 Diesel

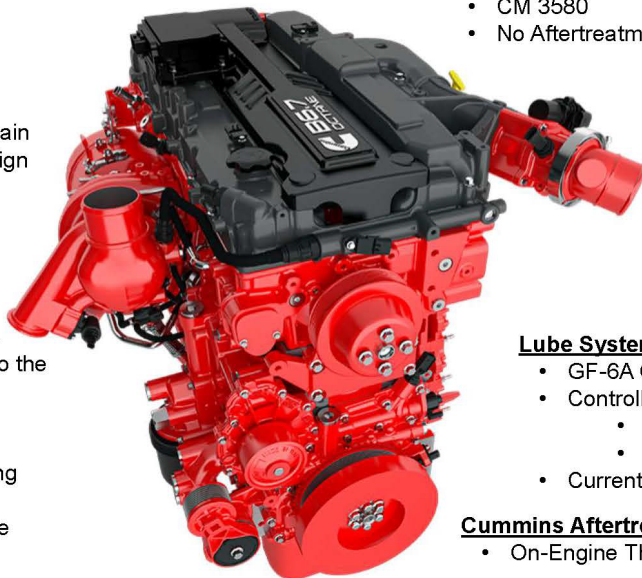

### Electronics/Controls

- CM 3580
- No Aftertreatment Control Module

### Fuel and Ignition System

- Direct Injection
- 350 bar Fuel Pressure
- M14 Spark Plug
- Coil-on-Plug Connection
- Single 3/8" Quick Fuel Disconnect OEM Connection
- EVAP Purge Valve 1/2" Quick Disconnect OEM Connection

### Lube System

- GF-6A Oil Required (10w30 and 15w40)
- Controllable Piston Cooling Nozzles
  - Solenoid actuated
  - Independent feed rifle
- Current Product Spin-On Oil Filter

### Cummins Aftertreatment System

- On-Engine Three Way Catalyst (TWC)



# Cam Phasing and Integrated Exhaust Brake

## Cam Phasers

- Same phaser PN on intake and exhaust with 50 crank degree phasing capability.
- Oil fed through two OCVs, 1 for intake cam 1 for exhaust cam to control phasing independently.
  - OCV – Oil Control Valve
- Unique cam cap#7 with oil circuit to provide oil supply from cylinder head → OCVs → Cam cap #7 → Cam Journal #7 → Oil drillings on the camshaft nose → Phasers

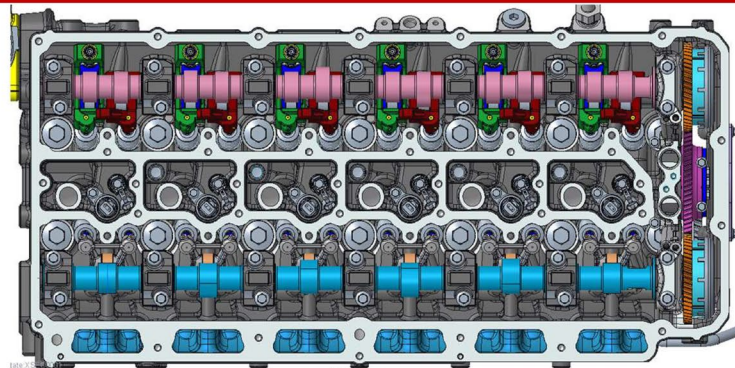
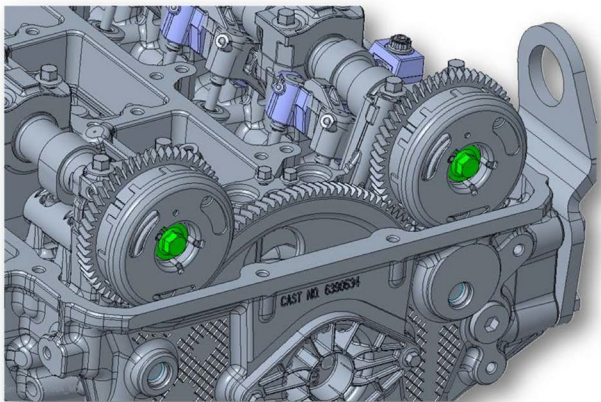

Oil Flow thru  
Cam to Phaser

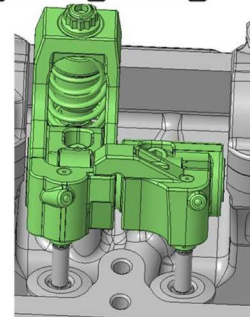
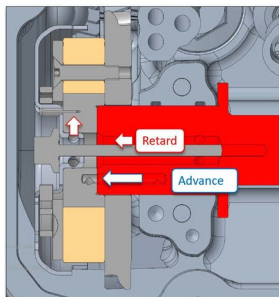

No lash  
adjustment  
required on  
engine brakes  
after leaving  
factory



# Spark Plugs, Coils, and Extensions

Sparkplugs	75K mi
Ignition Coil Extensions	150K mi

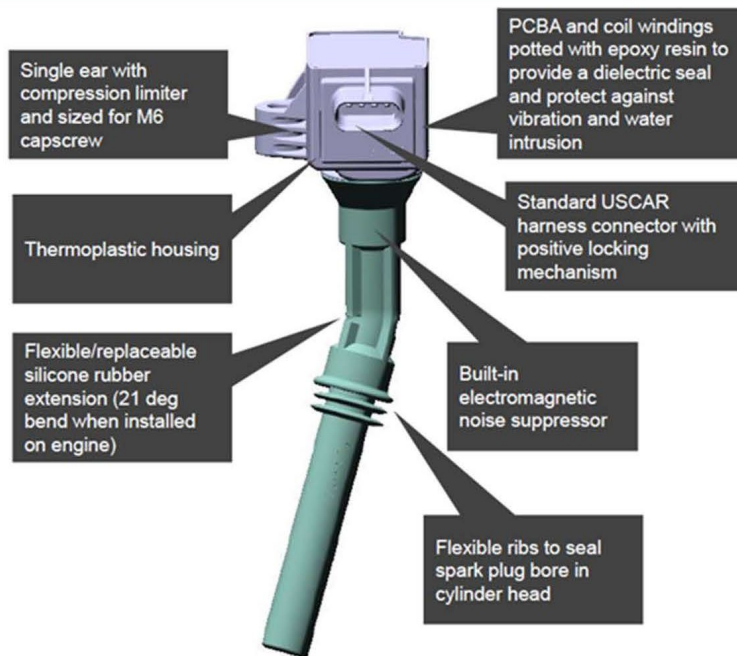
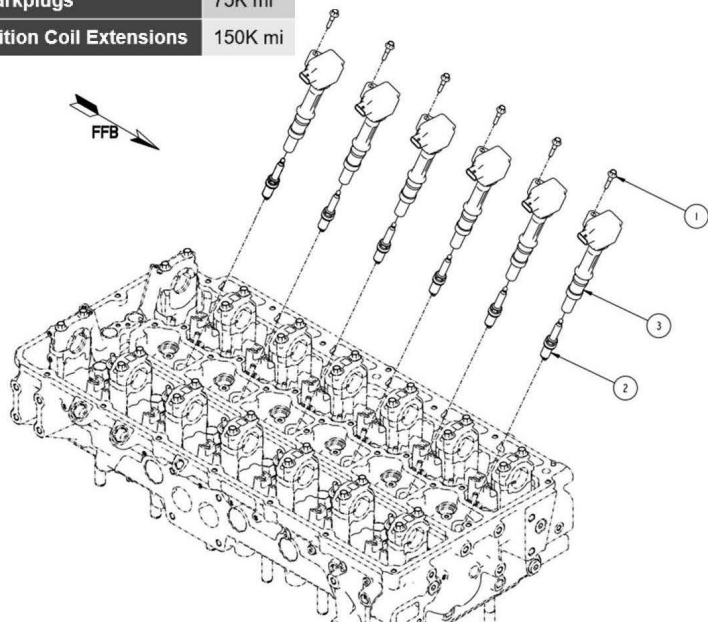

**B6.7 Octane**

B6.7 Octane details are preliminary and may be subject to change at any time without notice.



# Maintenance Targets - Preliminary

Maintenance Event	B6.7 Octane TARGET
Oil and Filter Change	Up to 15,000 mi / 600 hr. / 12 mo. (duty cycle dependent)
Fuel Filter Change	No Specified Interval (OEM supplied)
Crankcase Ventilation Filter ("Breather") Change	Maintenance Free
Valve Lash Adjust	N/A (HLA)
DPF Clean	N/A
DEF Filter Change	N/A
Spark Plugs	75K mi
Ignition Coil Extensions	150K mi



**B6.7** Octane

B6.7 Octane details are preliminary and may be subject to change at any time without notice.



# Oil and Filter

## Oil and Filter Change

Up to 15,000 mi / 600 hr. / 12 mo.  
(duty cycle dependent)

### • OIL

- **Valvoline Premium Blue™ One Solution Gen 2**
- GF6-A – 10W-30 or 15W-40
- GF6-B (Zero Weight Oils) are **not approved**
- 15 Quart Pan Capacity

### • FILTER - LF3970

- Existing location and filter

### • COOLANT

- Fleetguard ES COMPLEAT™ OAT or equivalent (CES 14636)



B6.7 Octane details are preliminary and may be subject to change at any time without notice.

**B6.7 Octane**



ENGINES

# B7.2

## New displacement, same class-leading dependability

Introducing the new Cummins B7.2, a diesel engine that brings state-of-the-art advanced technology to the proven, dependable B-platform for medium-duty and vocational applications. Built on 40 years of data and experience from the legendary B6.7 diesel, the B7.2 will have increased capabilities and options with the power and durability you have come to expect from the B series.

[VIEW SPECIFICATIONS](#) ↓

[REQUEST A QUOTE](#)

Power  
**240 - 340 hp**  
179 - 254 kW

Torque  
**650 - 1000 lb-ft**  
881 - 1356 N·m

Certification  
**EPA 2027**

Product Availability  
**North America**

Applications

MEDIUM-DUTY TRUCK

VOCATIONAL

SCHOOL BUS

TRANSIT BUS

RECREATIONAL VEHICLES



**Specifications** Ratings

**Specifications**

<b>HORSEPOWER</b>	240 - 340HP (179 - 254 kW)
<b>PEAK TORQUE</b>	650 - 1,000 lbs. - ft (881 - 1356 Nm)
<b>GOVERNED SPEED</b>	2400 rpm
<b>NUMBER OF CYLINDERS</b>	6
<b>BORE AND STROKE</b>	107 mm x 133 mm
<b>ENGINE WEIGHT (DRY)</b>	1,359 lbs (616.43 kg)
<b>SYSTEM WEIGHT (DRY)</b>	1,607 lbs (727.92 kg)
<b>AFTERTREATMENT WEIGHT</b>	248 lbs (112 kg)

