

BRAUN

C O R P O R A T I O N

Troubleshooting Guide

BRAUN **MILLENNIUM** **SERIES**

BRAUN **CENTURY** **SERIES**

BRAUN **VISTA** **SERIES**

Reference material only; consult owner
manual for details

33870 Rev E



Serial Number Identification Tag

Letters for Series Code

The Braun Corporation
1-800-THE LIFT™
BRAUNLIFT.COM™

DOT Public Use Lift MODEL#
NL917FIB-2

Max. Lifting Capacity 800lbs.

SERIAL NUMBER
AA-00025

PUMP CODE CYLINDER
64 **14BI**

MFG DATE
06/23/06

CE e5*72/245*95/54*0110*00
PATENT
PENDING- 5,261,779-6,065,924-6,238,169-6,46
4,447-6,599,079-6,692,217-6,739,824

Numbers for Series Code

The Braun Corporation
1-800-THE LIFT™
BRAUNLIFT.COM™

DOT Public Use Lift MODEL#
NL917IB

Max. Lifting Capacity - 800 lbs.

SERIAL NUMBER
02-00025

PUMP CODE CYLINDER
55 **14CG**

MFG DATE
05/24/05

CE e5*72/245*95/54*0110*00
PATENT
PENDING- 5,261,779-6,065,924-6,238,169-6,46
4,447-6,599,079-6,692,217-6,739,824

Warranty Card

- ◆ Must be filled out to activate the 5yr warranty
- ◆ One copy for the dealer & one for end user
- ◆ Fill out the warranty card and send it in.

OWNER'S WARRANTY REGISTRATION

INCLUDE NO. **L917IB 44-03318 30 14DE**

NAME _____ OWNER _____ DATE FINANCED _____

ADDRESS _____

CITY _____ STATE _____ ZIP _____

TELEPHONE _____

TO VALIDATE WARRANTY
REGISTRATION CARDS MUST BE RETURNED TO THE BRAUN CORPORATION.

OWNER'S WARRANTY REGISTRATION

INCLUDE NO. **L917IB 44-03318 30 14DE**

NAME _____ OWNER _____ DATE FINANCED _____

ADDRESS _____

CITY _____ STATE _____ ZIP _____

TELEPHONE _____

TO VALIDATE WARRANTY
REGISTRATION CARDS MUST BE RETURNED TO THE BRAUN CORPORATION.

BRAUN MILLENNIUM SERIES



BRAUN CENTURY SERIES



One piece activation foot

BRAUN VISTA SERIES



Lift Terminology

NHTSA Millennium Lift

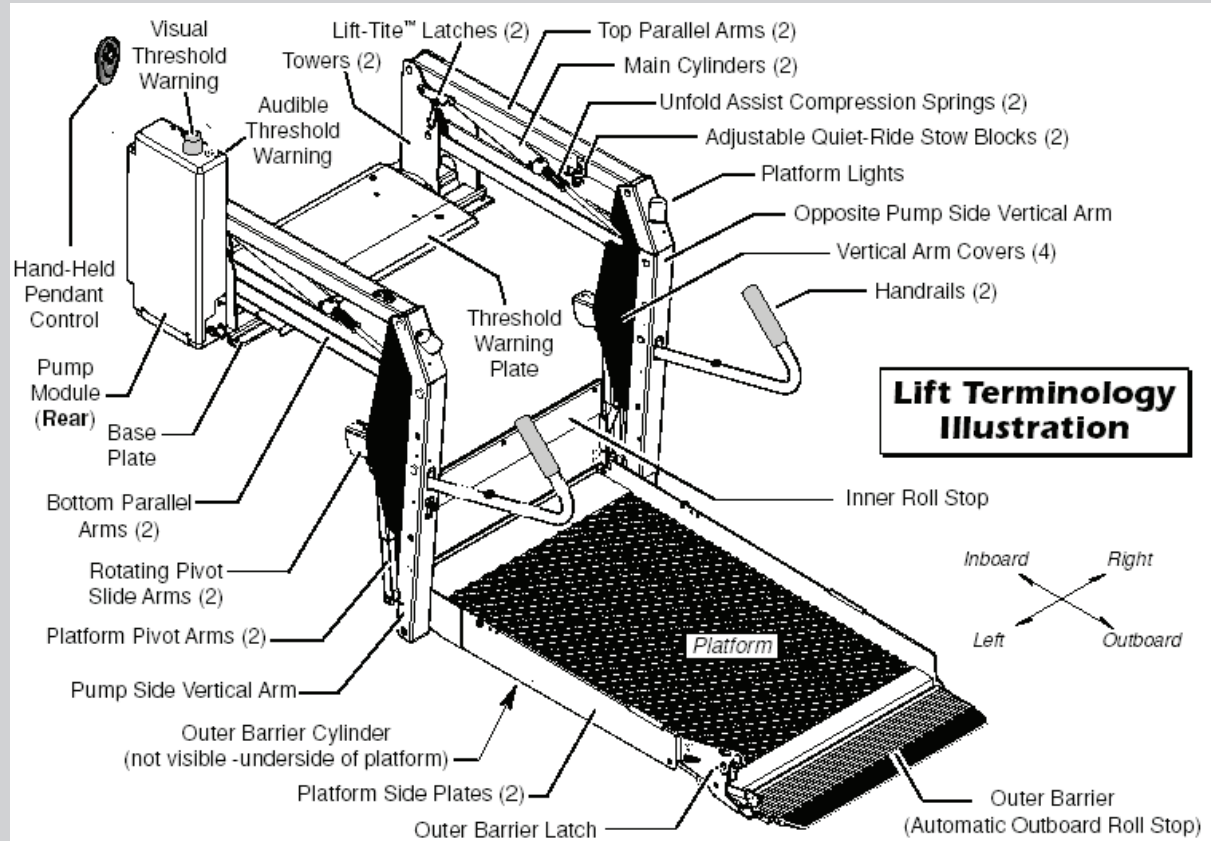

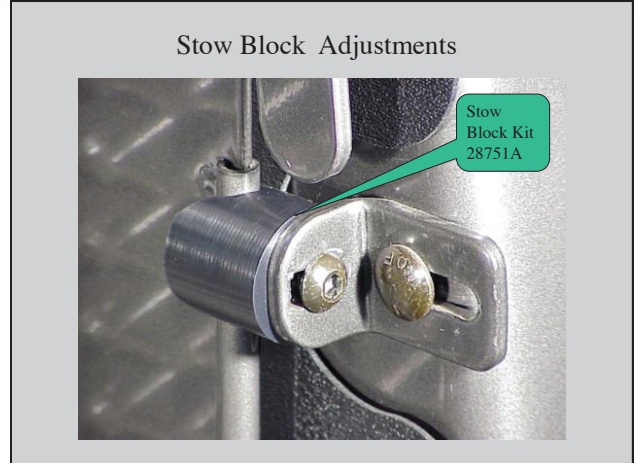
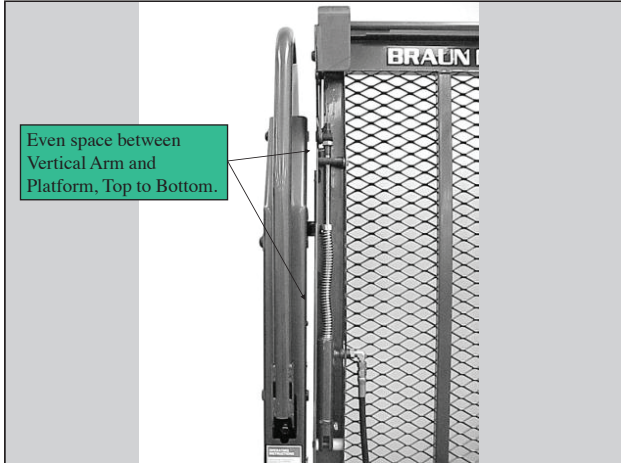

Lift Adjustments

Loosen Here

Tighten Here

To Correct:

Tighten Here

Loosen Here

To Correct:

Base plate shim # 34939ks

Base Plate Shim 34939

Lift Base

Millennium Platform Angle Adjustment

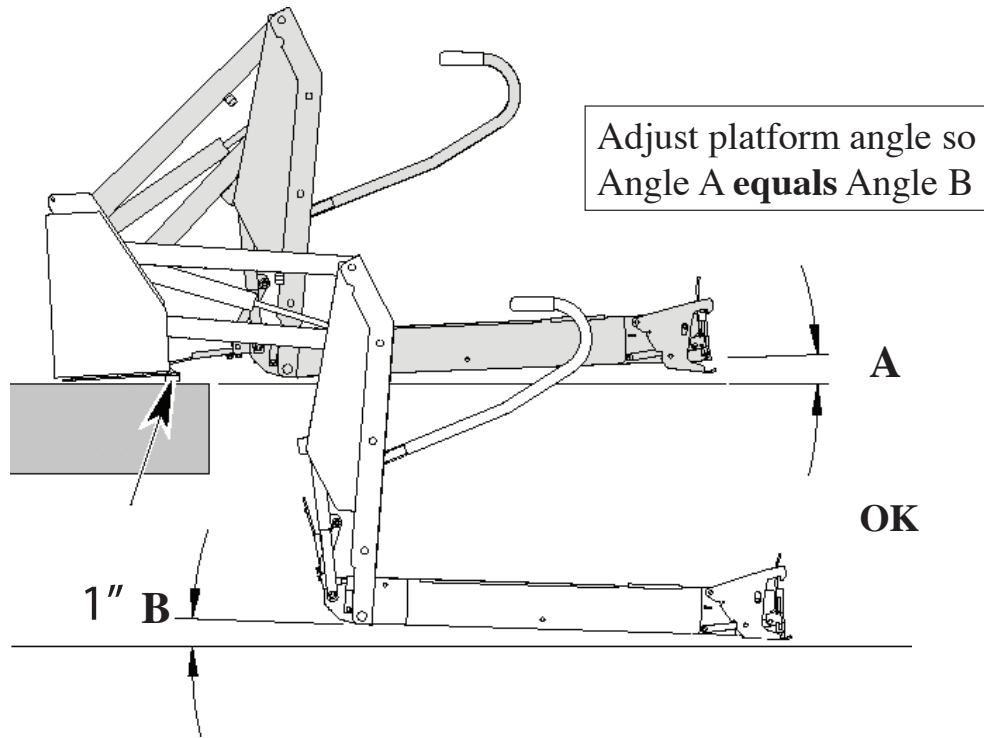

Century/Vista Platform Angle Adjustment

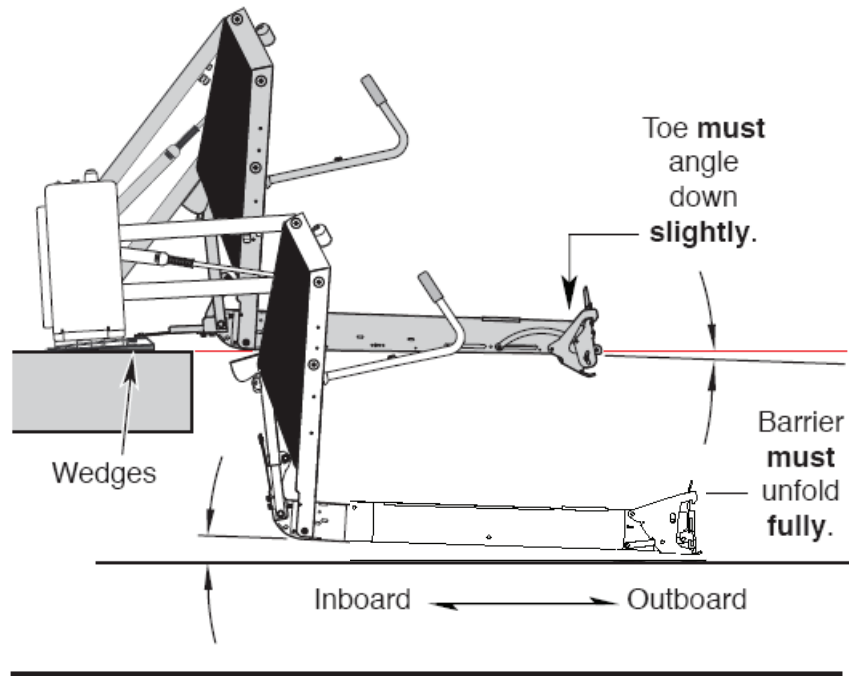

Tower Microswitch Adjustment

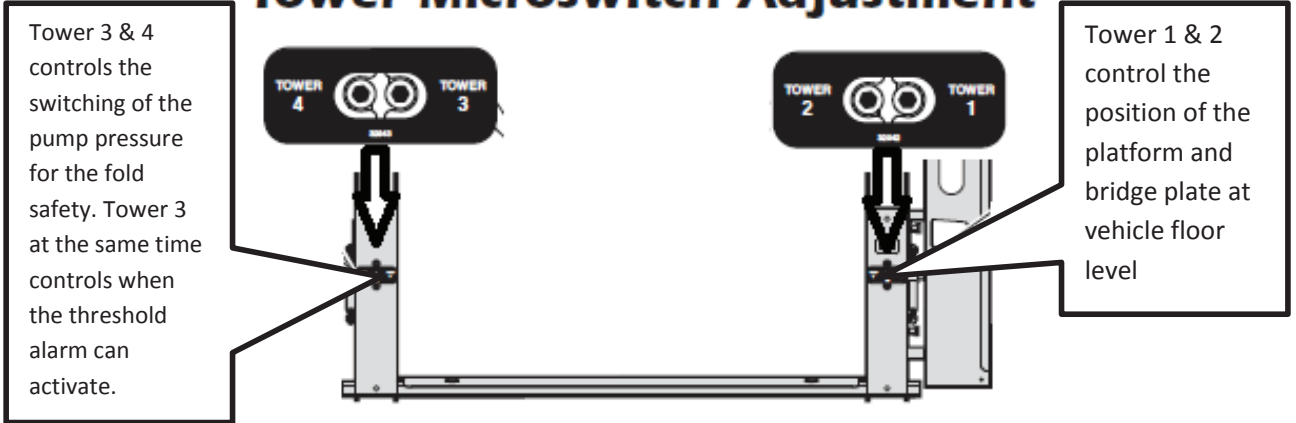

Tower #3: Threshold alarm activation and fold pressure.
Tower #4: switches the pump back to full pressure

Tower #1: Unfold switch adjustment
Tower #2: Up switch adjustment

Note: tower 1 & 2 will always be next to the pump assy.

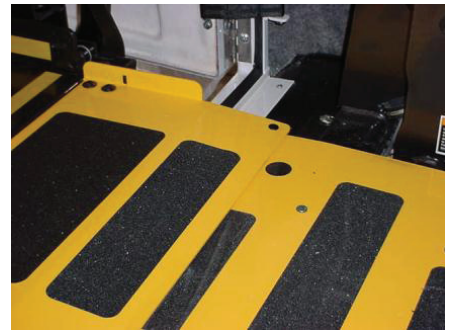
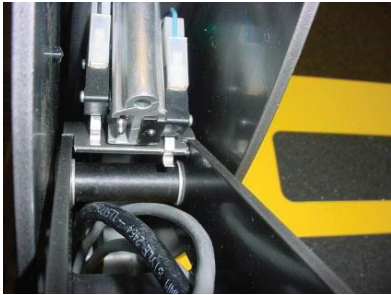

The pictures are of tower 3 & 4 and the platforms bridge plate at vehicle floor level. Please note tower three is even with the aluminum extrusion and tower 4 is back in the slot about 3/8"

Platform fold
adjustment screw



Outter barrier Relief adjust
Millennium only

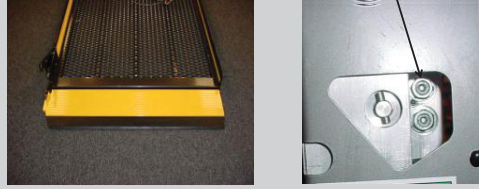

Dual Relief
Adjustment
century or vista

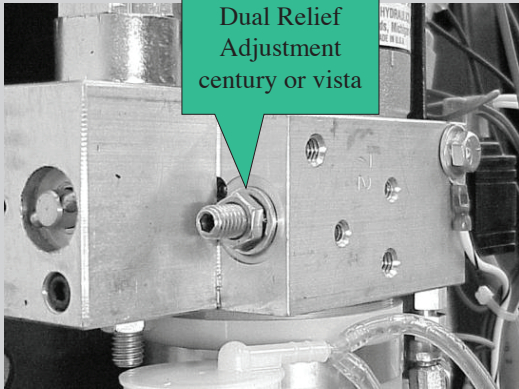

9/16 Ford spark plug socket



NL-2 Hydraulic Pump Valves

VALVE EXPLANATION

OUTER BARRIER
CLOSED VALVE
(the platform will not
move unless this valve
is energized)

FOLD RELIEF VALVE
(platform will not pick
up 800 lbs unless
energized)

OUTER BARRIER
DOWN VALVE
(outer barrier deploy)

DOWN VALVE
(main lifting cylinders)

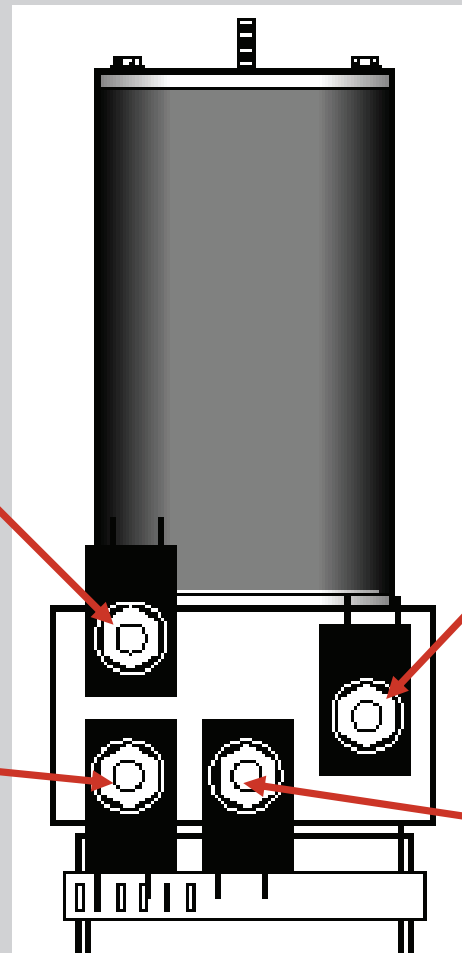

PLATFORM DRIFTING ISSUES

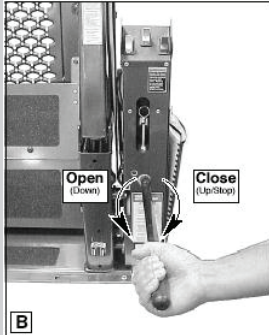
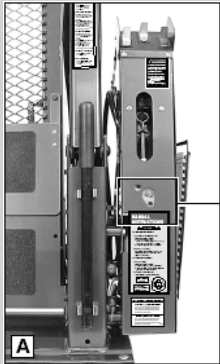

Release Valve

approximate 1/16" intervals

maximum 30 inch lbs
minimum 15 inch lbs
seats (stops)

Valve Tightening Specification:
Once valve seats (stops), tighten 15 to 30 inch pounds as shown.

OPEN CLOSE

Release Valve

Note: Close backup pump release valve securely **before** operating electric pump.

- BACK UP PUMP VALVE SHOULD BE TIGHTENED AS SHOWN ABOVE
- IF NOT, LIFT WILL DRIFT

PLATFORM DRIFTING ISSUES

REMOVE VENT LINE FROM REAR OF ALL CYLINDERS

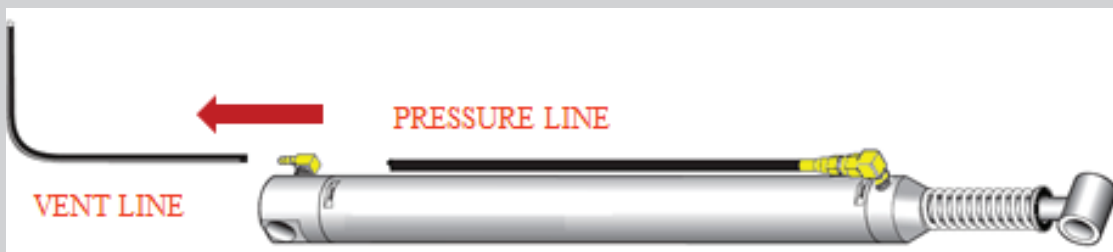

IF STEADY DRIP OR STREAM OF FLUID IS PRESENT,
REPLACE CYLINDERS

**MUST REMOVE LINE FROM FITTING ON CYLINDER,
NOT AT RESERVIOR CAP!!!**

Hydraulic fluid is Exxon Unavis HVI 26

Braun part number 32840ks

Lift must have a minimum of 11 volts while pump is running w/engine off !!

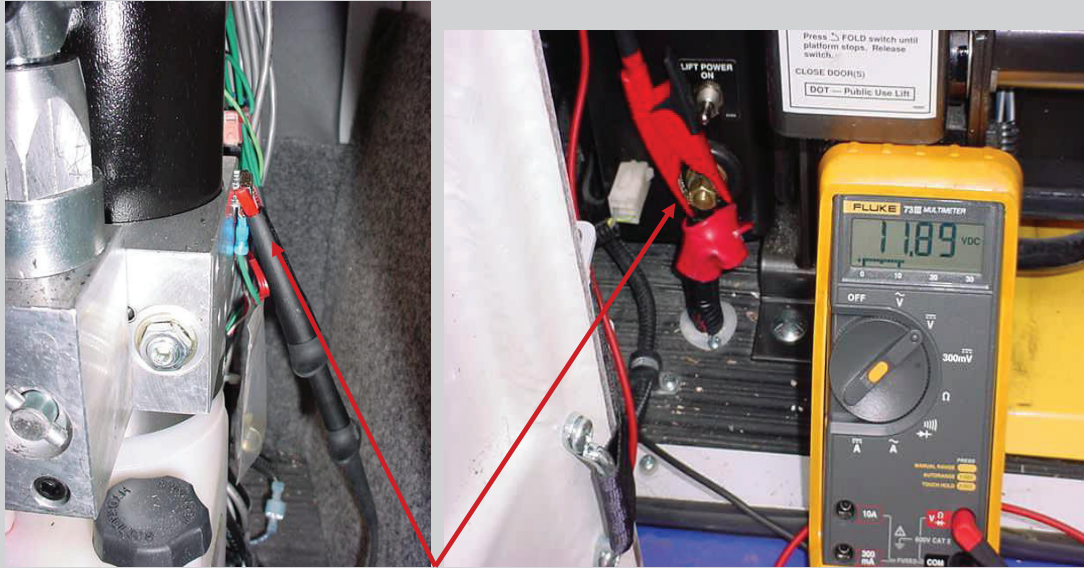

Volt meter com to pump ground
Red lead to power stud

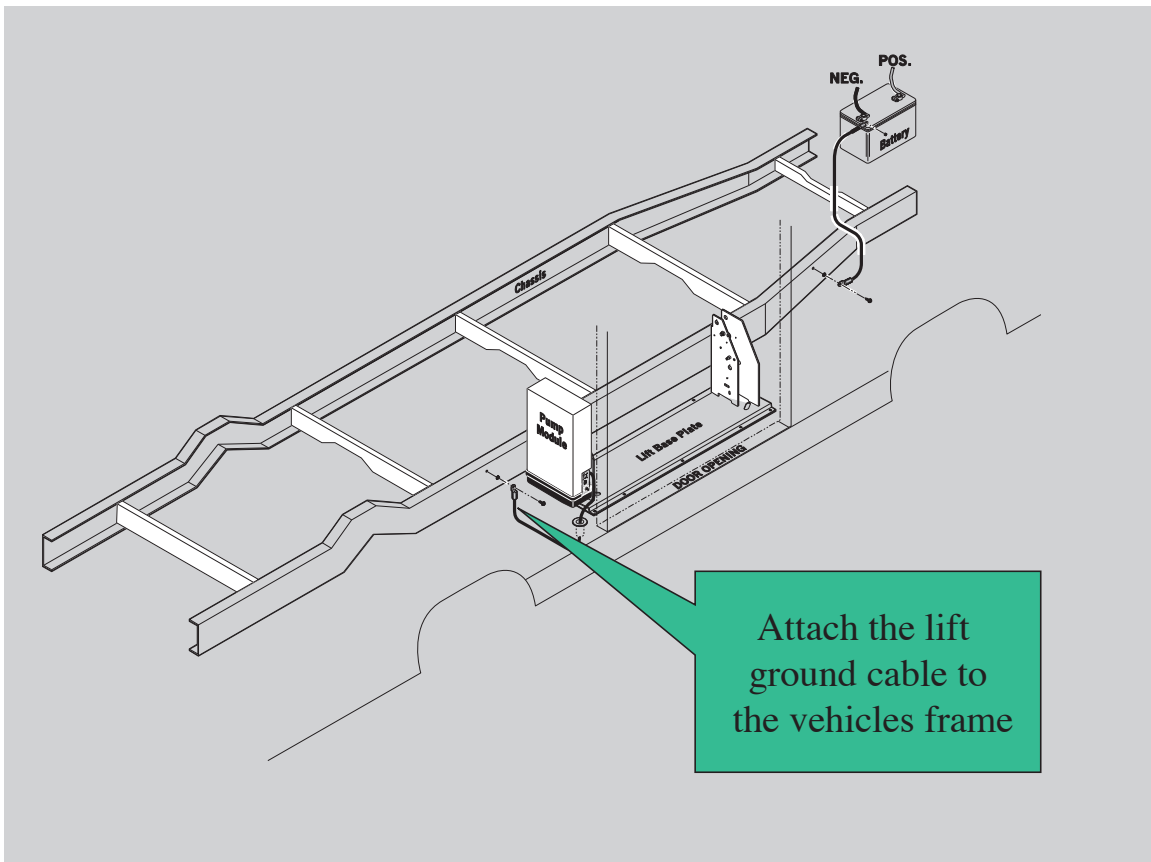

Lift Power Source

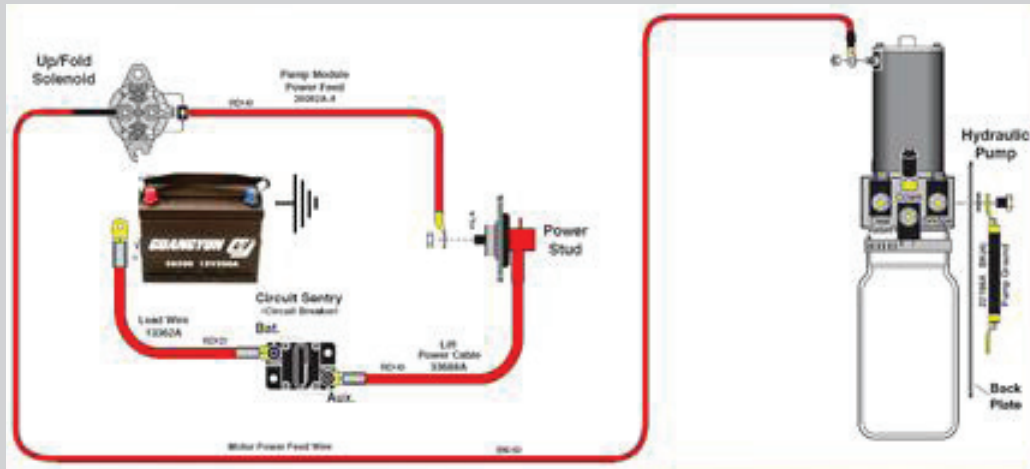

Interlock connection control circuit

12 volt supply on gray w/red

Interlock jumper prt # 31797A

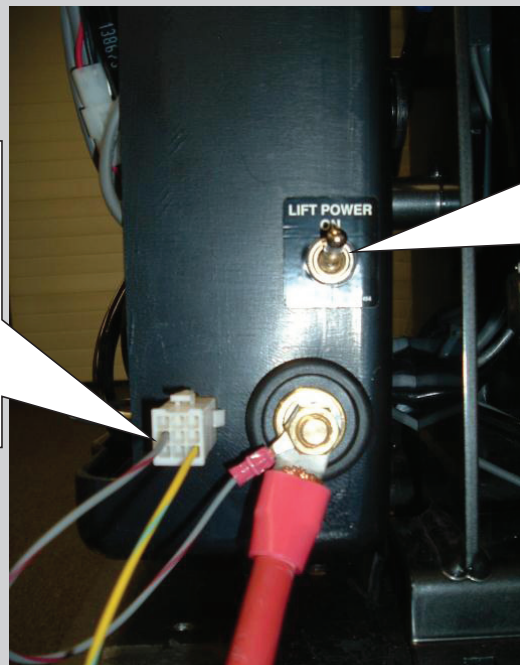

The interlock input is now a 12V signal

It supplies 12V to the on off switch

Redundant Relay Protects Against Welded Up Solenoid



Troubleshooting The Redundant Relay

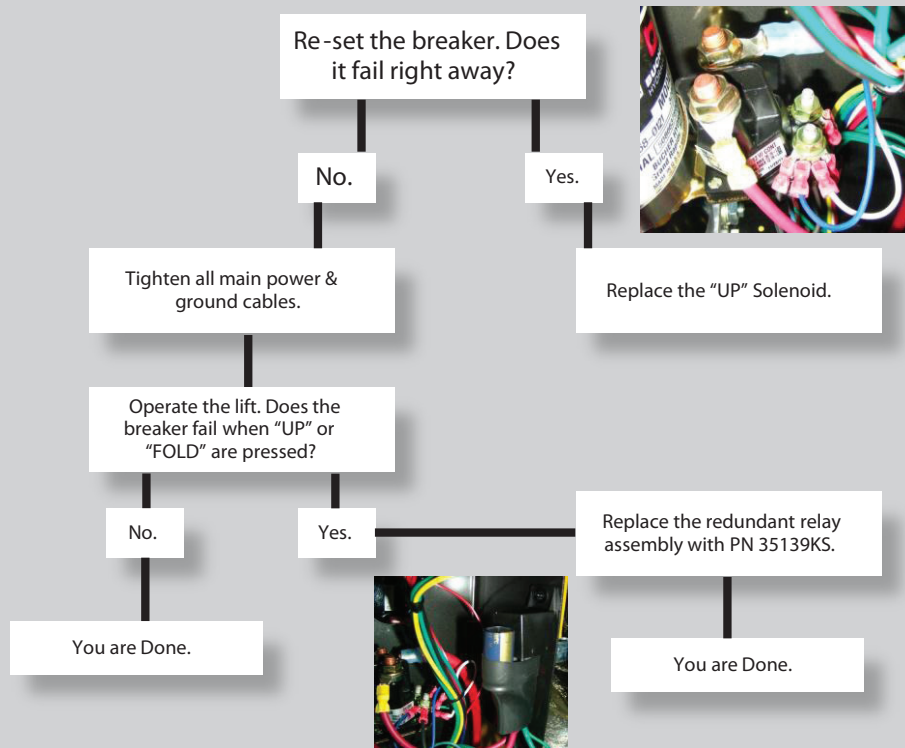

Switch and Sensor Locations

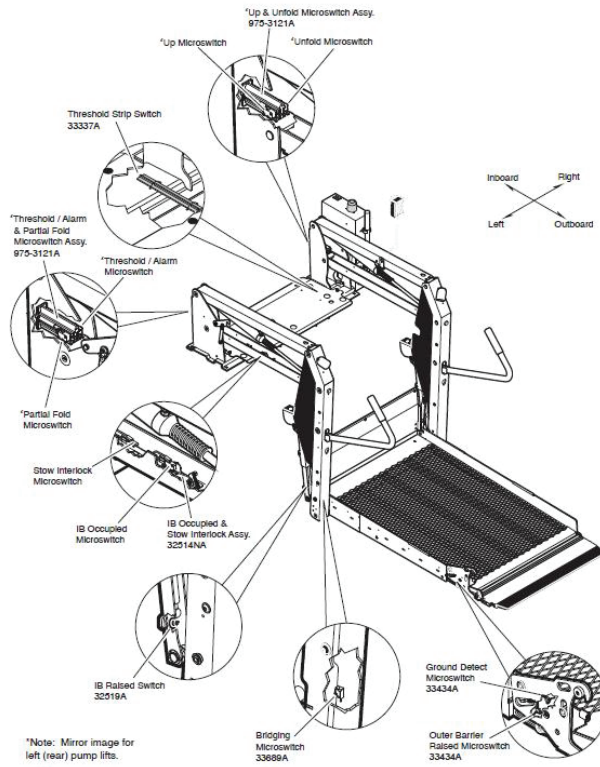

Switch and Sensor Locations

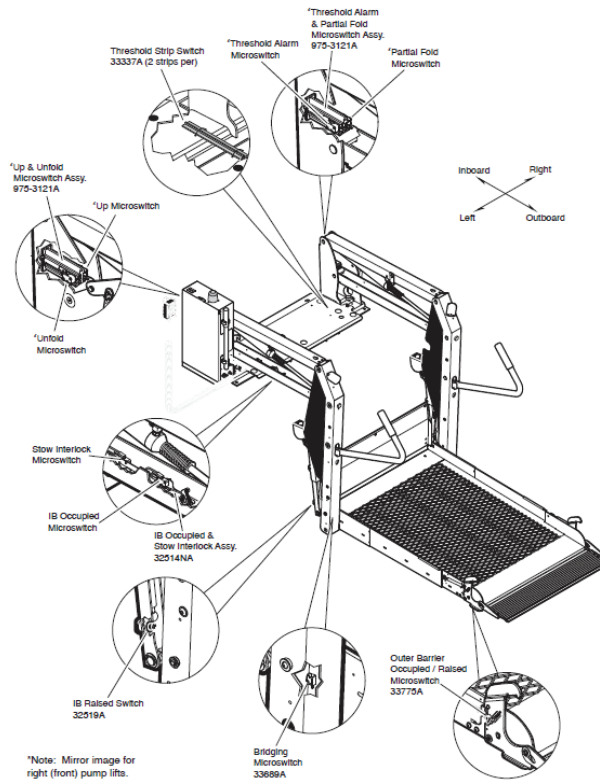

Troubleshooting Guide 33870

Non-electronic NHTSA DPA



ML
Millennium 2
Series



NCL
Century 2
Series



NVL
Vista 2
Series

GEN-2 Electrical Troubleshoot Procedure

1. Make sure lift is powered up correctly; all three lights should be on all the time. 1. Interlock Green LED; 2. Lift Lights; 3. Pendant illuminated
 - a. Green led not on; check vehicle interlock
 - b. Lift lights not on; check fuses or breakers inside pump box
 - c. Pendant lights not on; check IB barrier limit switches.
2. Once the lift is powered up, and the control pendant is illuminated, go to the highlighted circuit diagram pertaining to the lift function or cycle where the failure occurs. Use the component diagrams to identify the parts or components involved in that circuit. Trace the 12 volt signals from the pendant through the limit switches to the pump or solenoids to find your problem.
3. Refer to the proper series service manual for wire color and plug identification and any adjustments that may be needed.



One piece activation foot



Century Lift Power Circuit

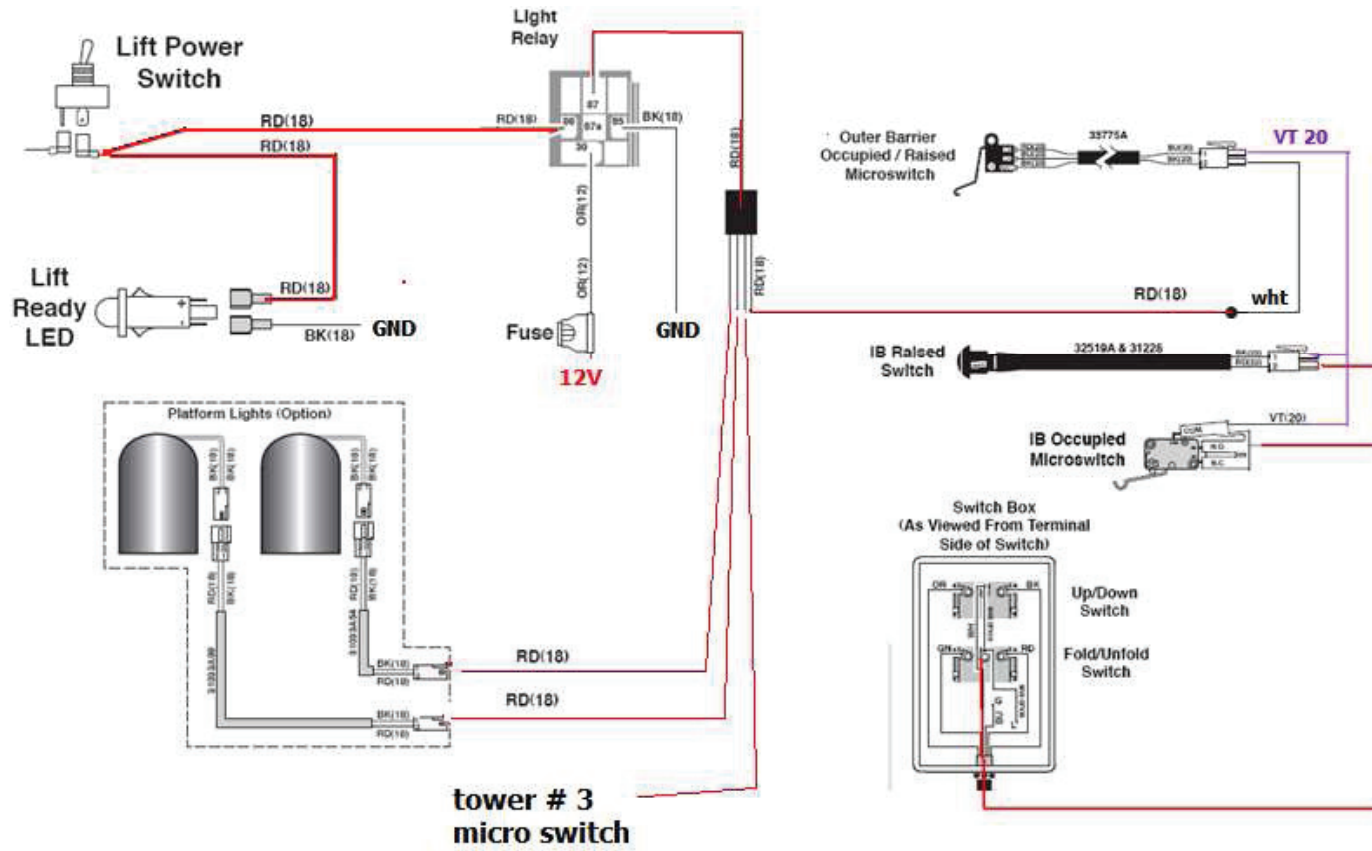

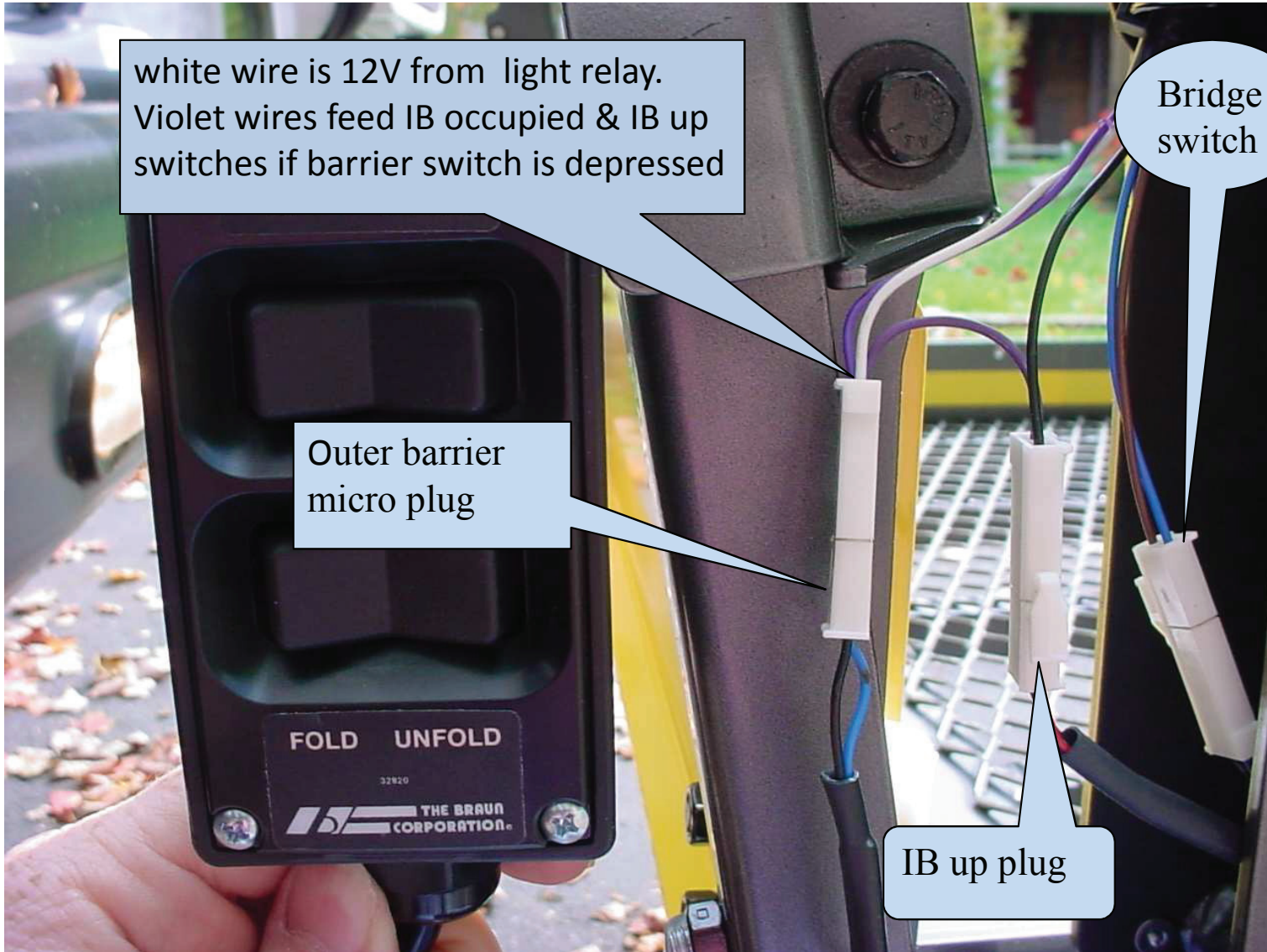

Testing White wire W/ Power Probe 12V from lift to barrier switches



Unfold Circuit

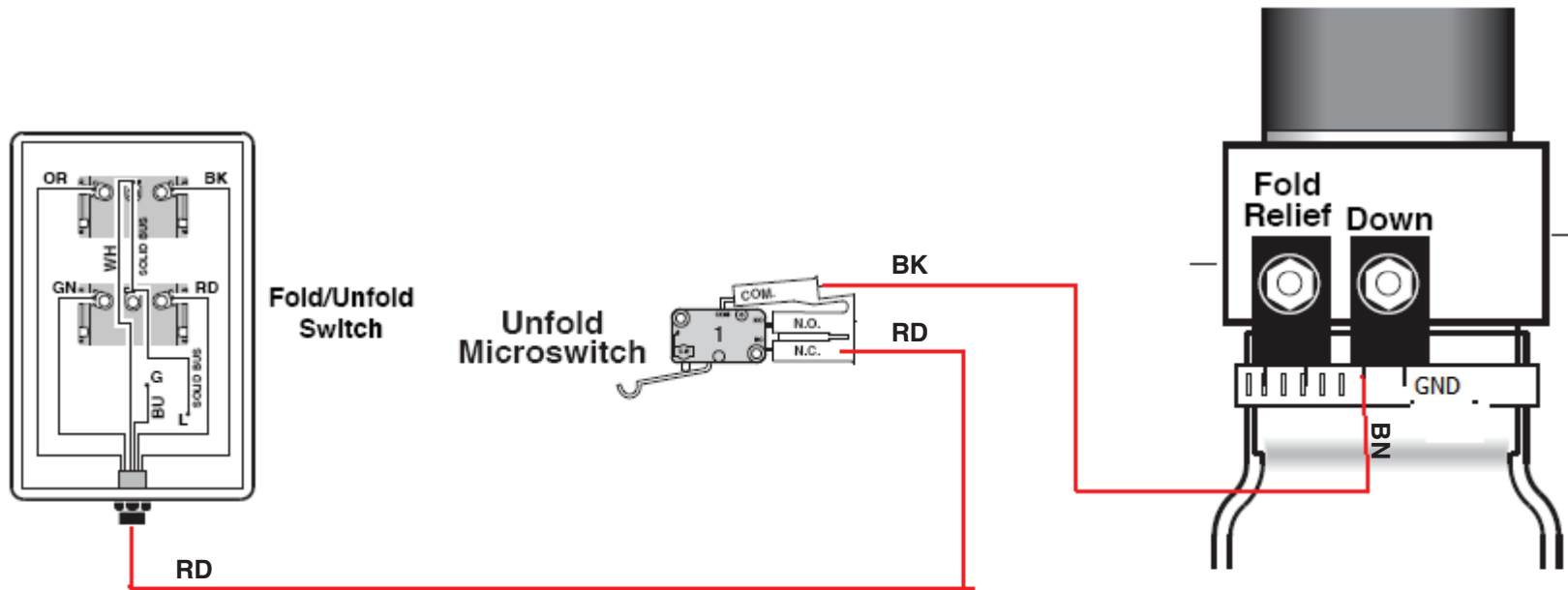

NCL -2 UNFOLD SCHEMATIC

Lift Electrical Schematic

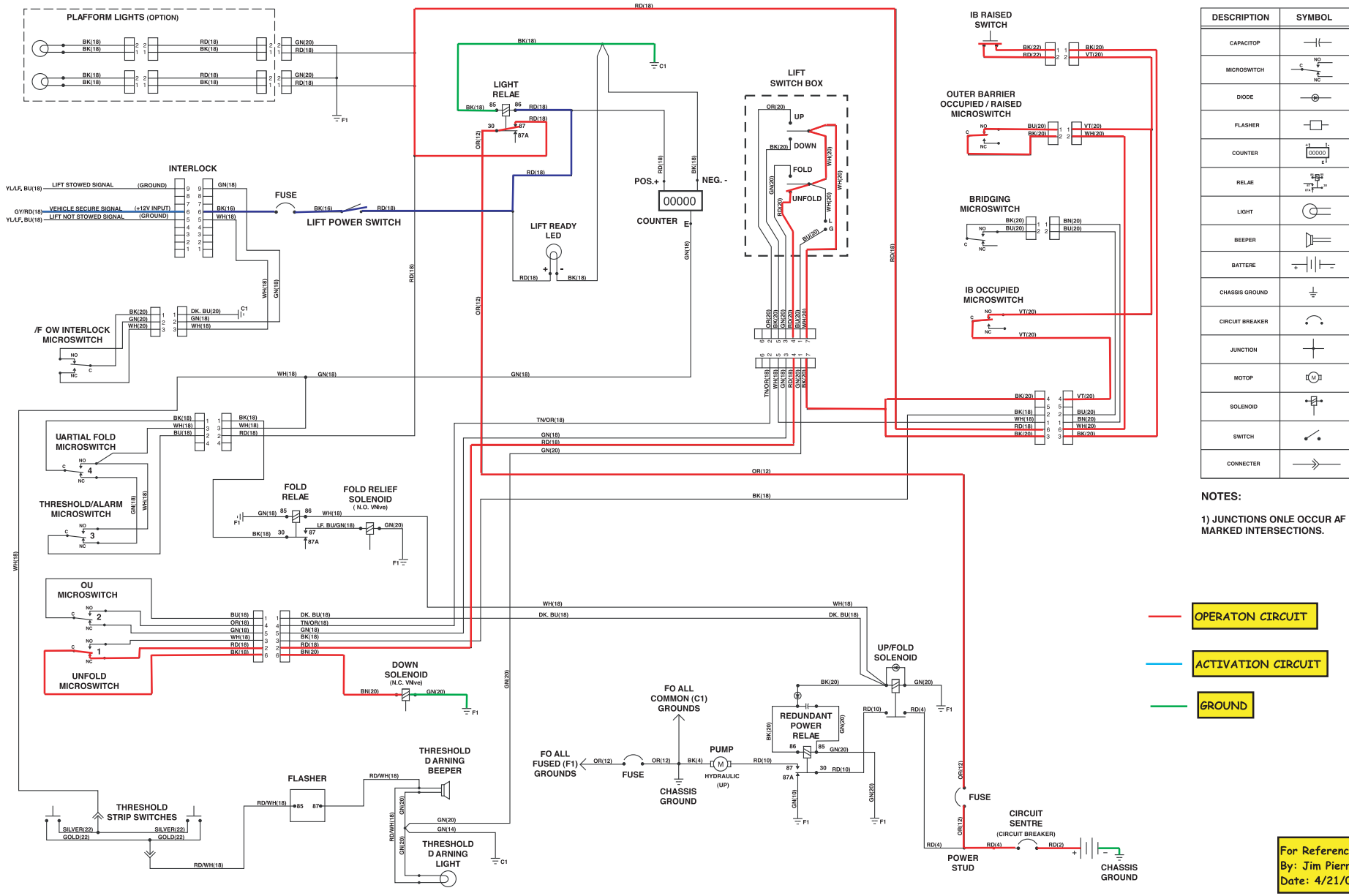

Down Circuit

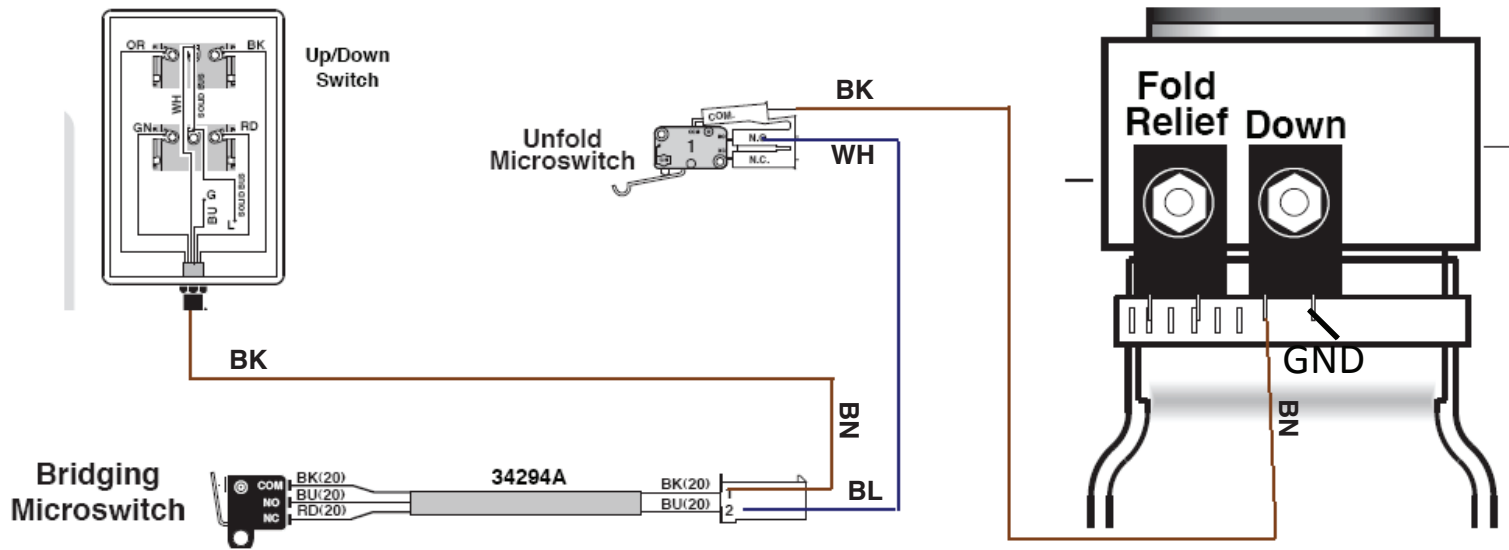

NCL -2 DOWN SCHEMATIC

Lift Electrical Schematic

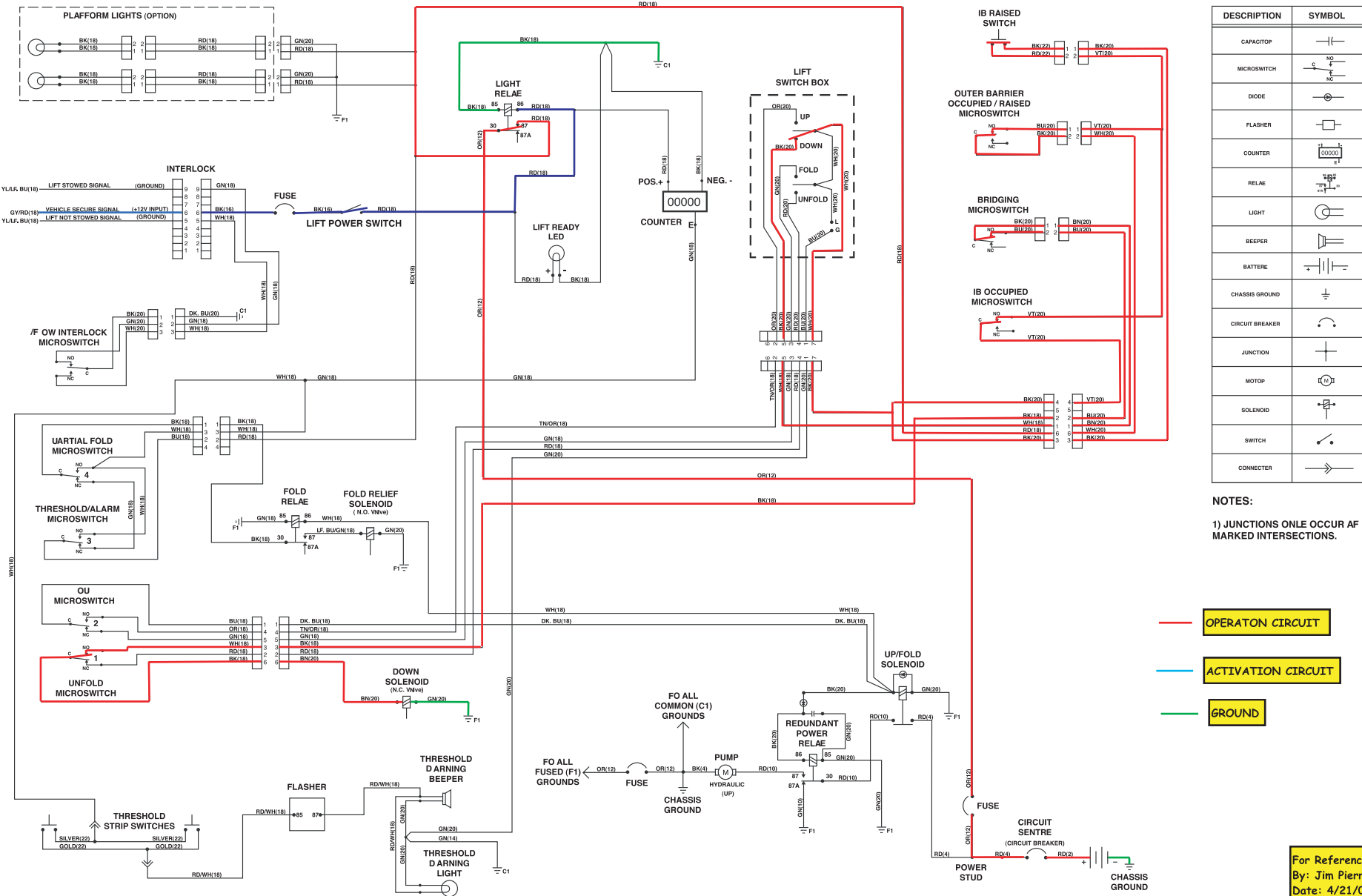

Up & Fold Circuit

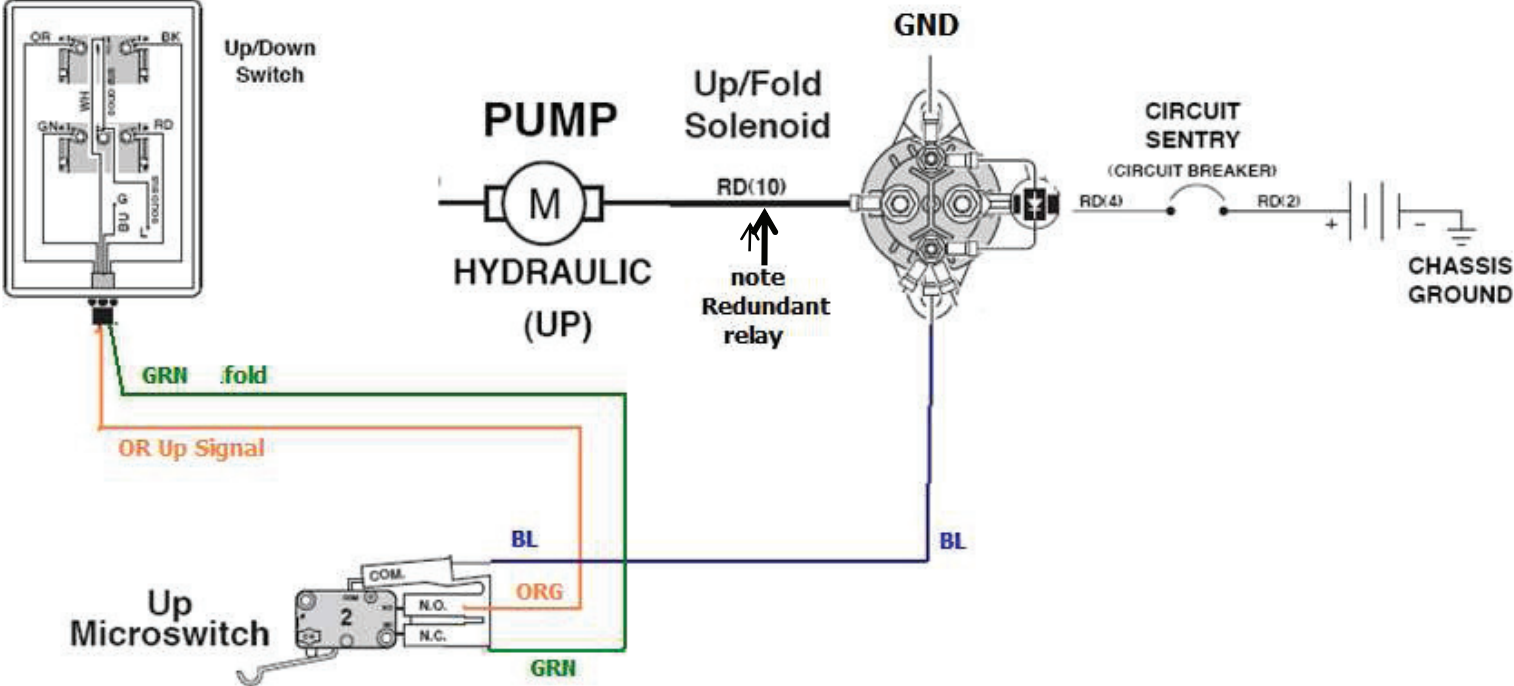

Platform Lifting up to 800 LBS

Tower 3 & 4 Micro Switches

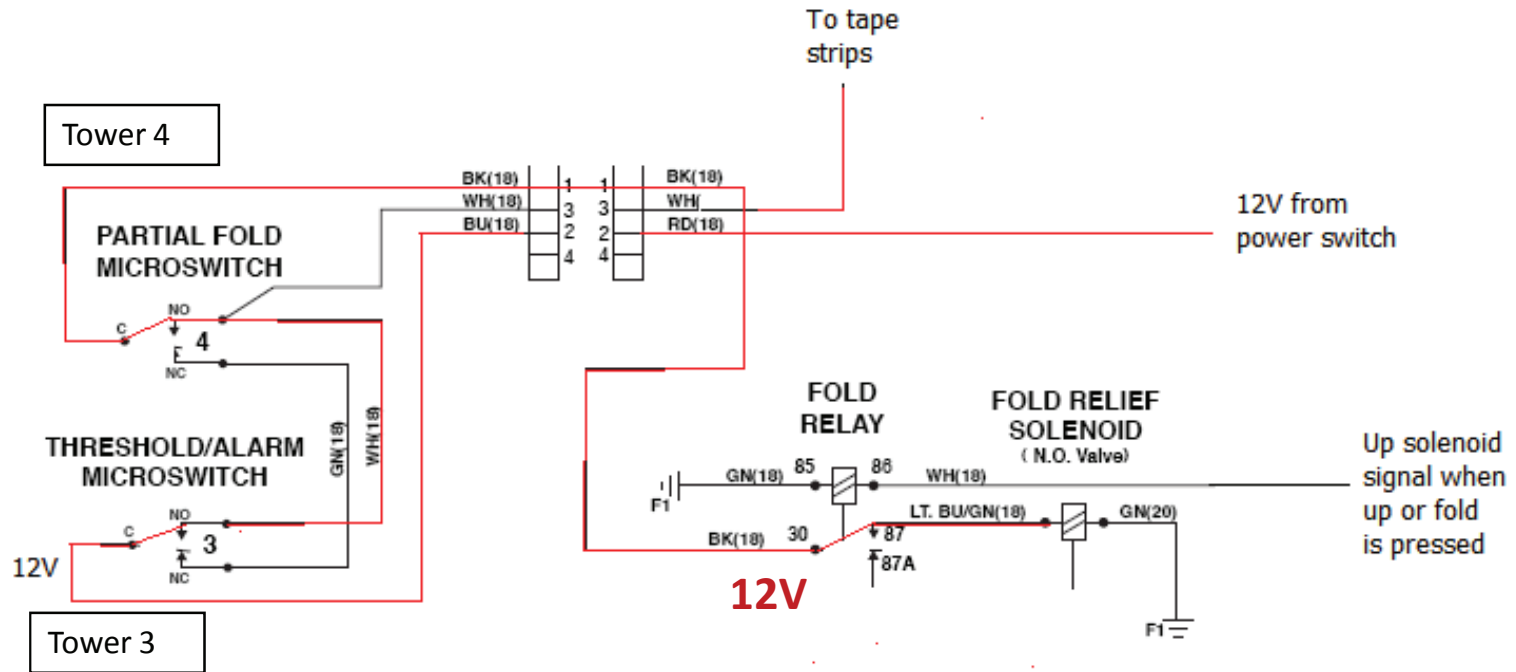

NCL -2 UP SCHEMATIC

Lift Electrical Schematic

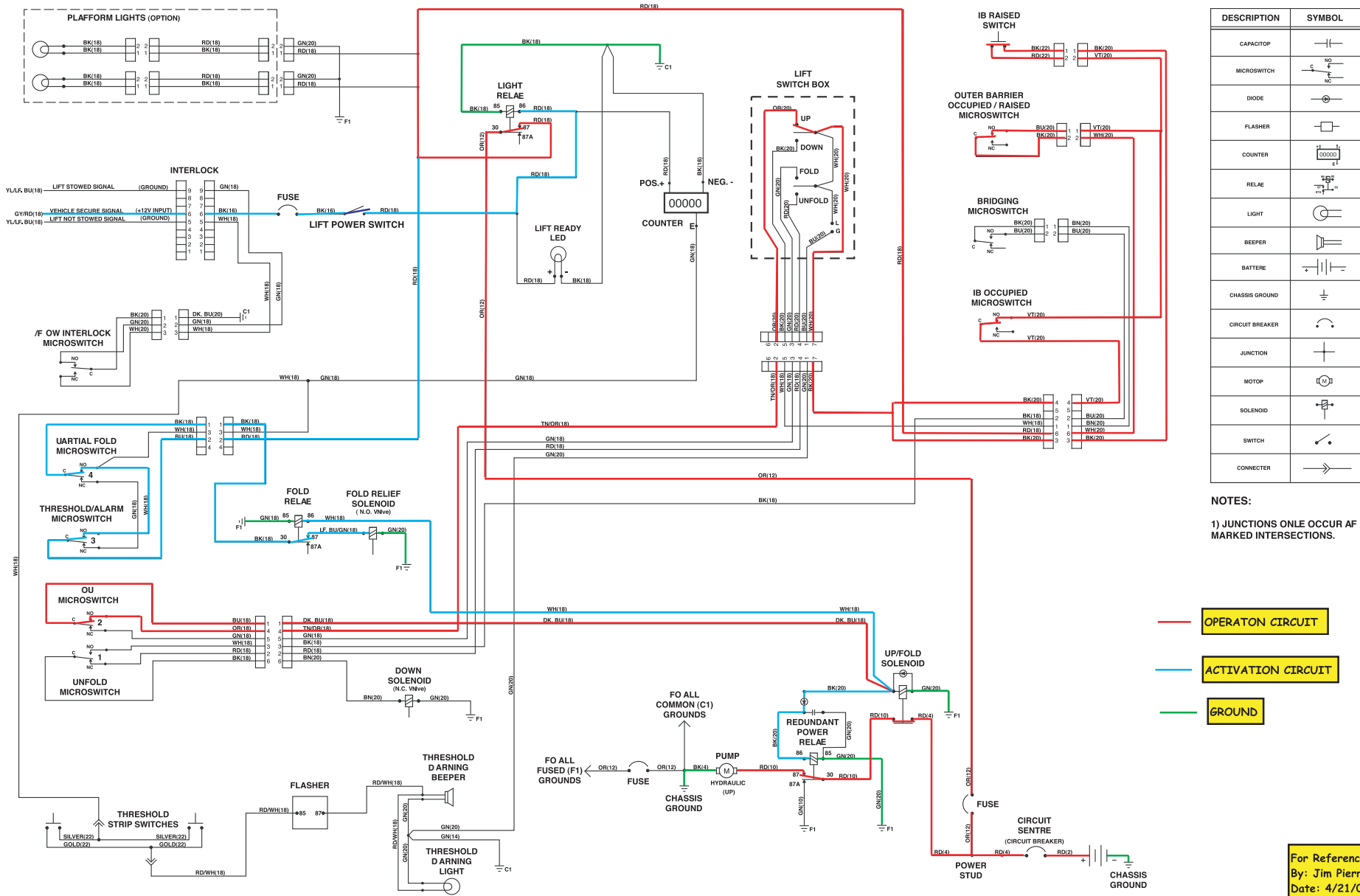

DESCRIPTION	SYMBOL
CAPACITOR	
MICROSWITCH	
DIODE	
FLASHER	
COUNTER	
RELAY	
LIGHT	
BEEPER	
BATTERY	
CHASSIS GROUND	
CIRCUIT BREAKER	
JUNCTION	
MOTOR	
SOLENOID	
SWITCH	
CONNECTOR	

NOTES:
 1) JUNCTIONS ONLY OCCUR AT MARKED INTERSECTIONS.

- OPERATION CIRCUIT
- ACTIVATION CIRCUIT
- GROUND

For Reference Only
 By: Jim Pierrou
 Date: 4/21/08

Platform Folding Limited Pressure

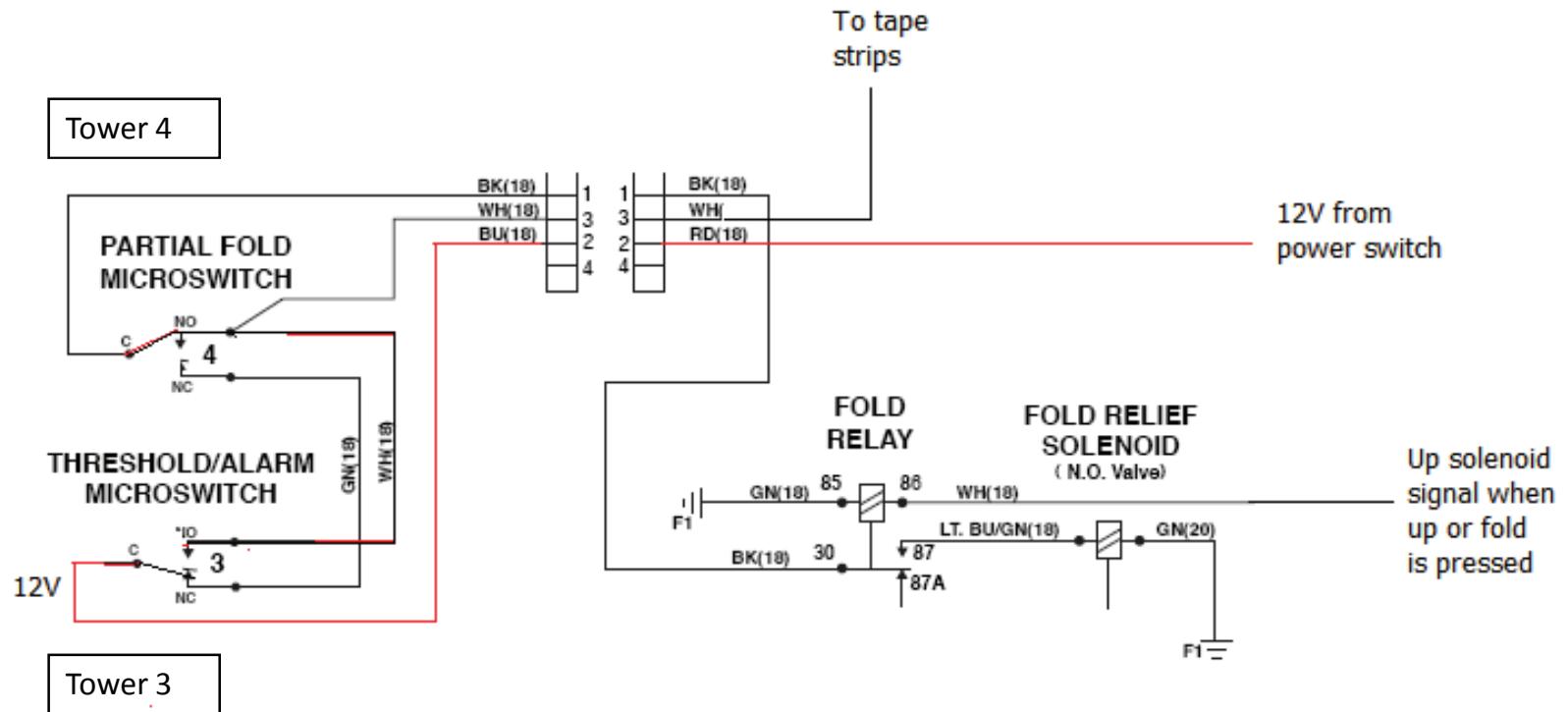

Platform folding under full pressure

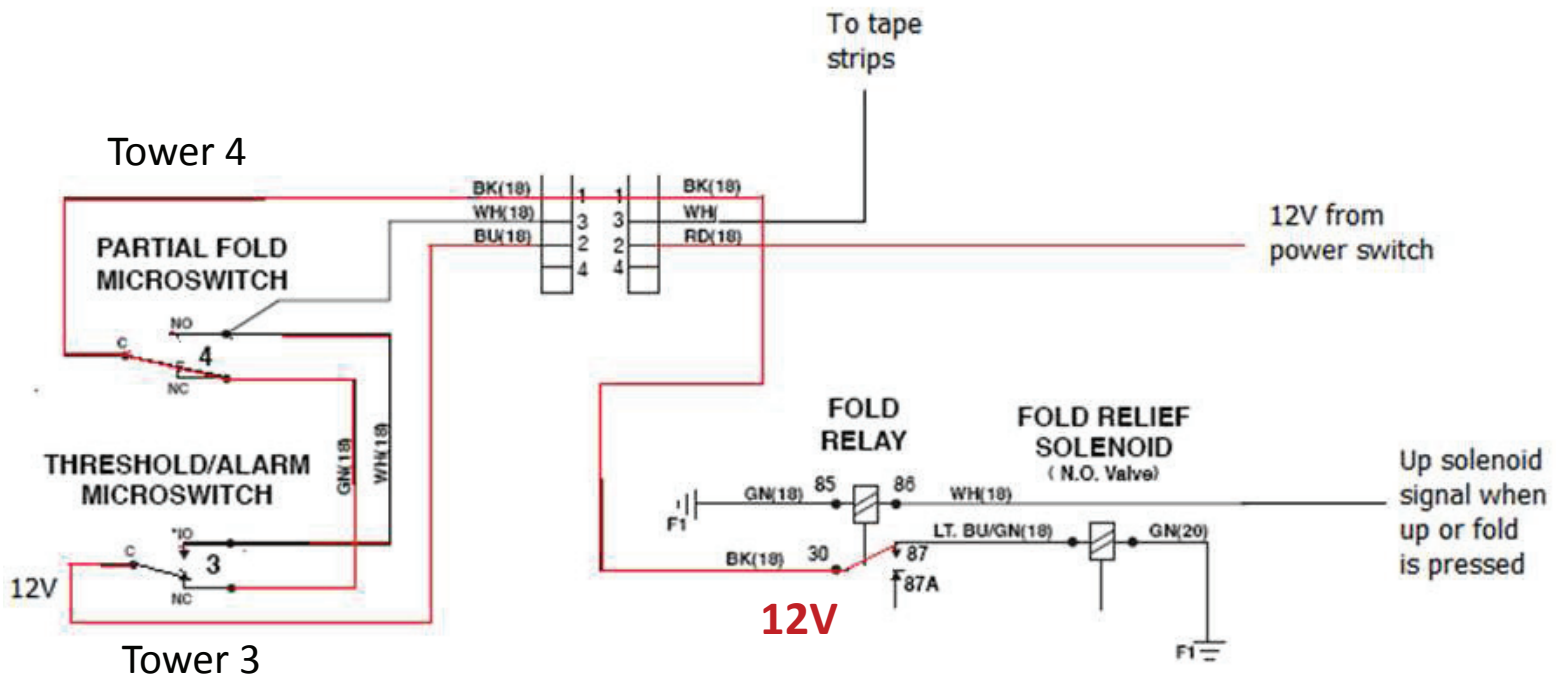

Power Redundant Relay Circuit

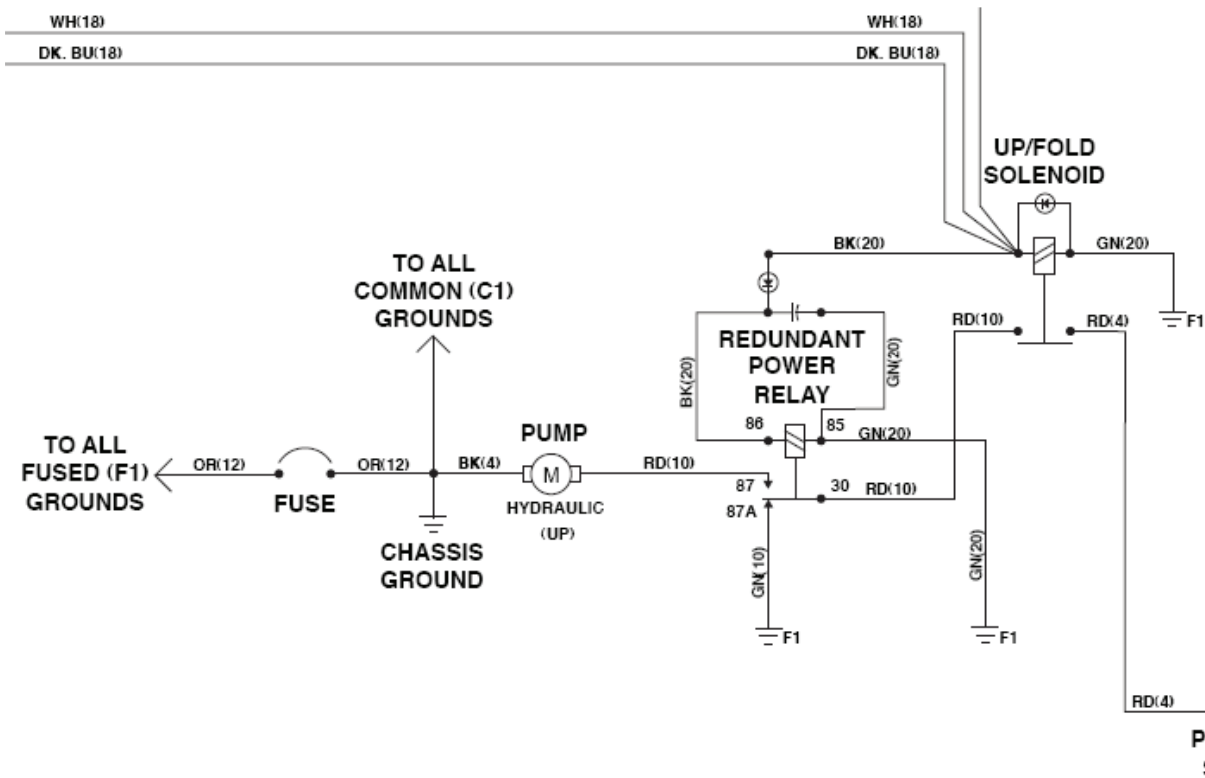

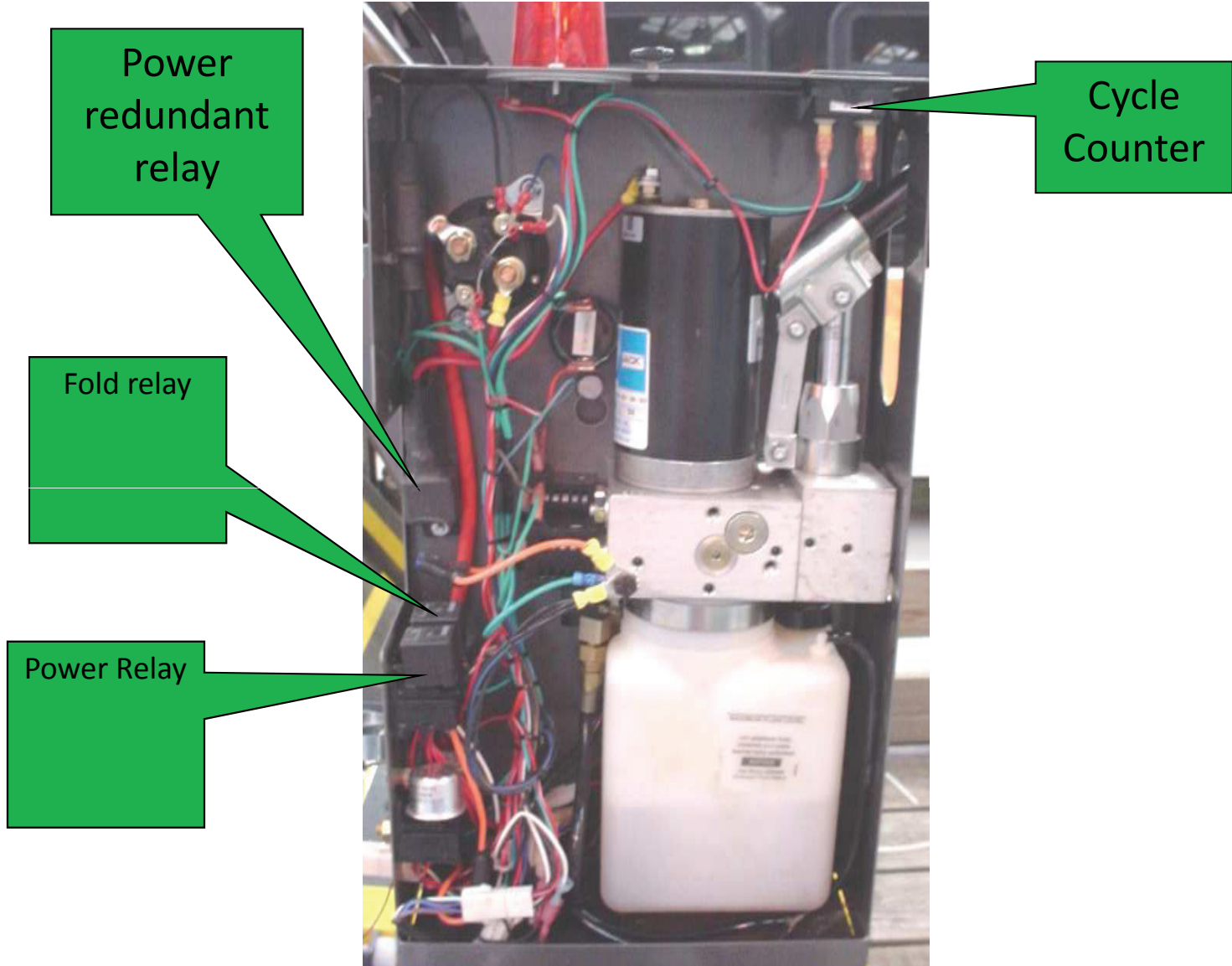

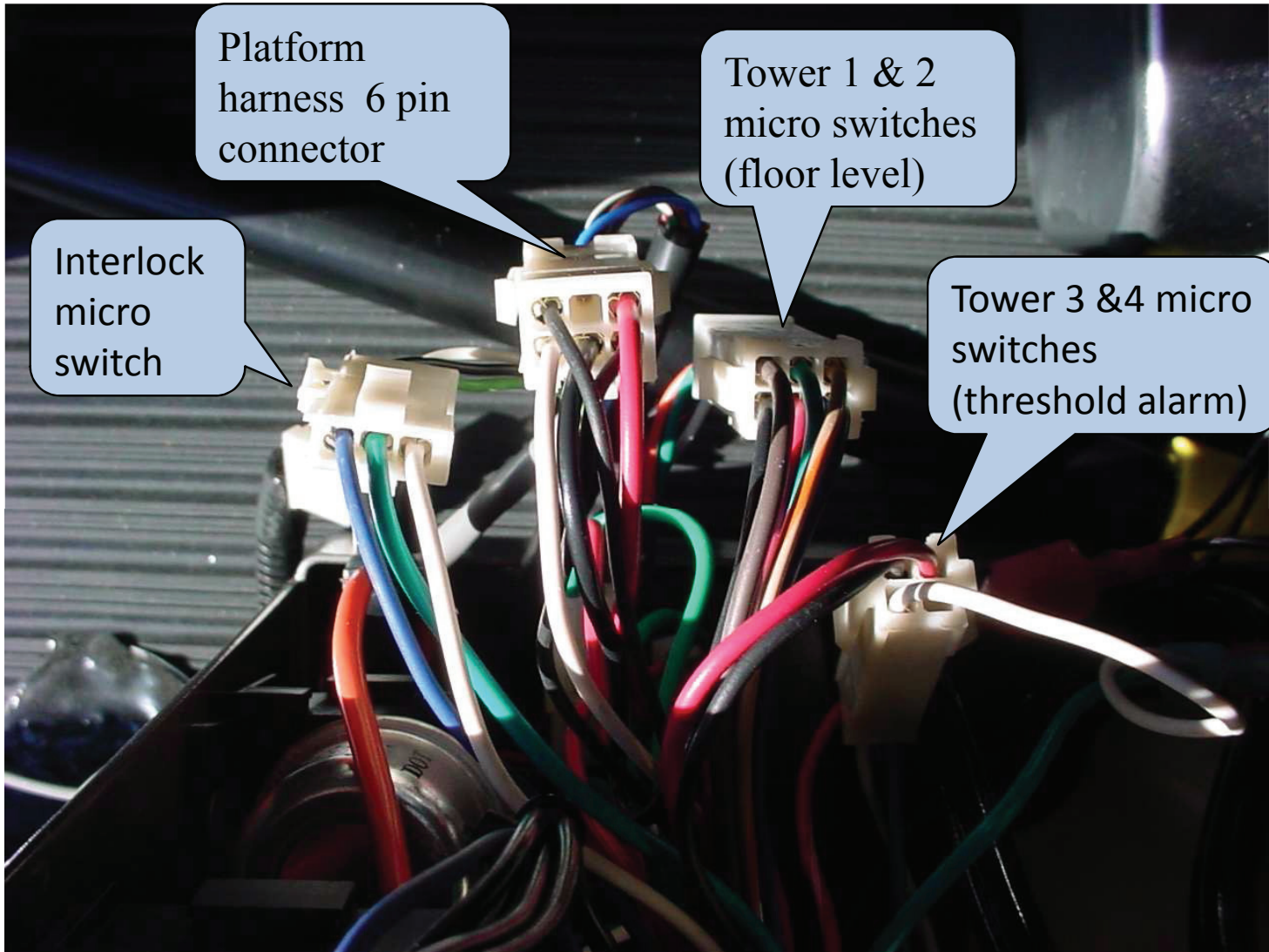

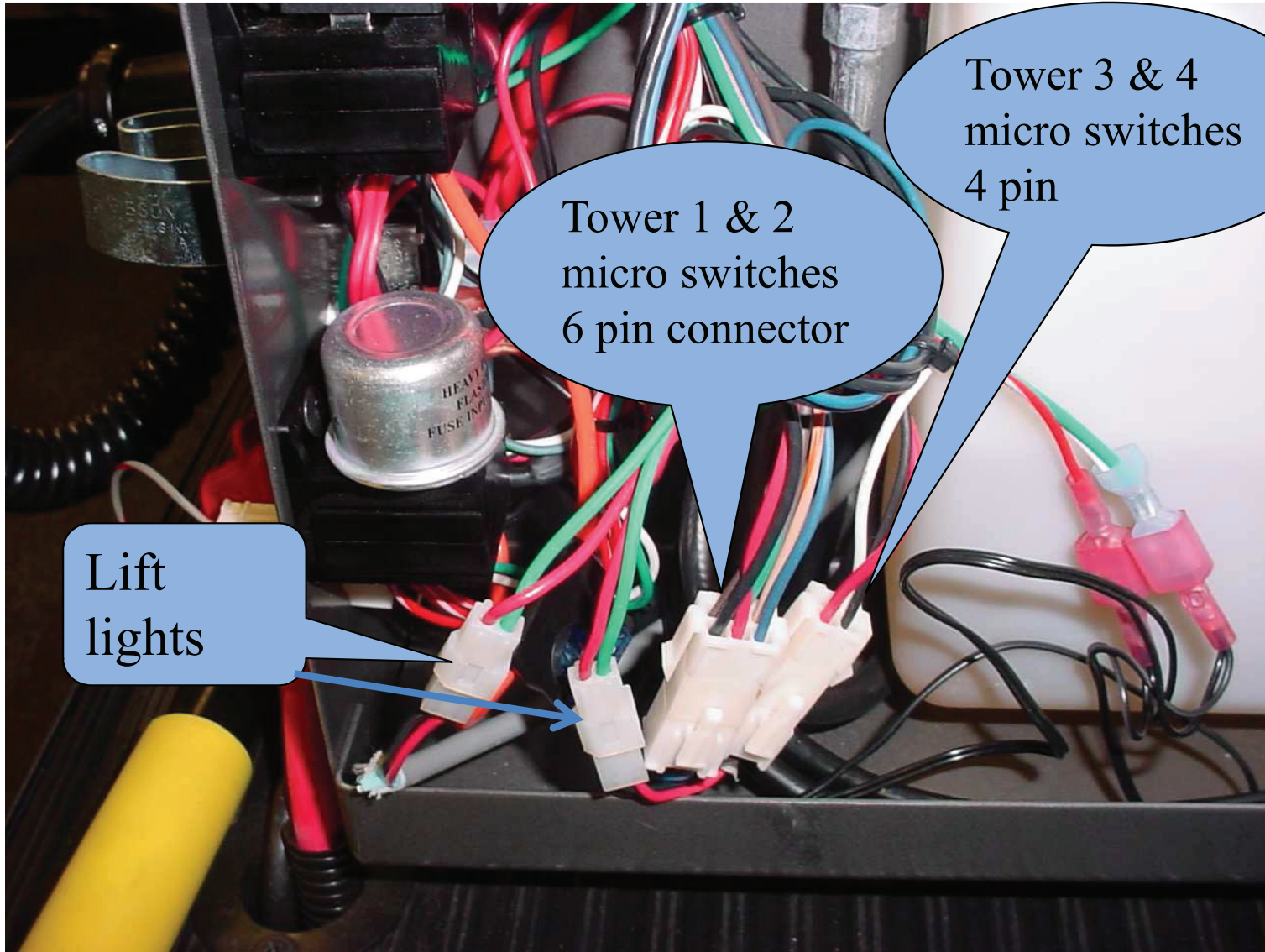

Lift
lights

Tower 1 & 2
micro switches
6 pin connector

Tower 3 & 4
micro switches
4 pin

BRAUN MILLENNIUM 2 SERIES™



Millennium Lift Power Circuit

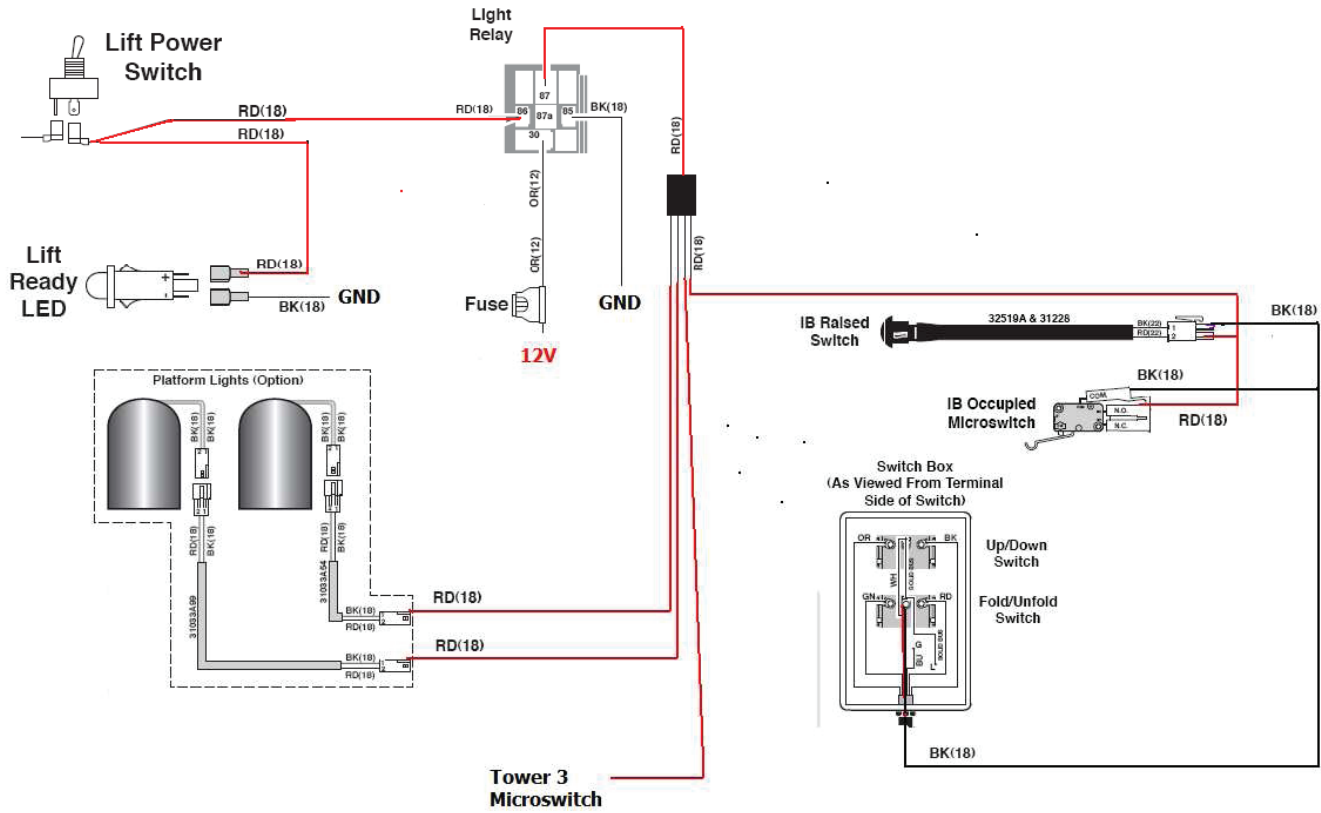

Millennium Unfold Circuit

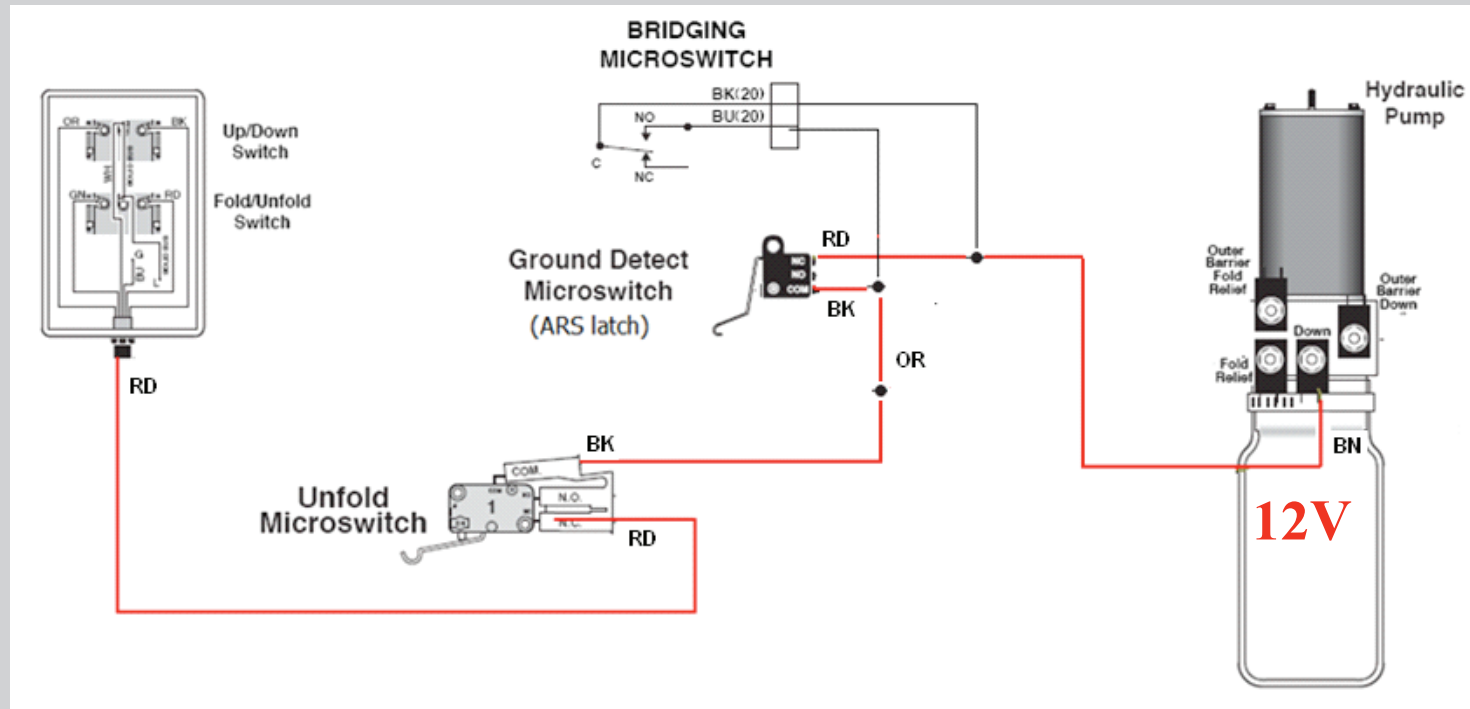

Lift Electrical Schematic

NL -2 Unfold Schematic

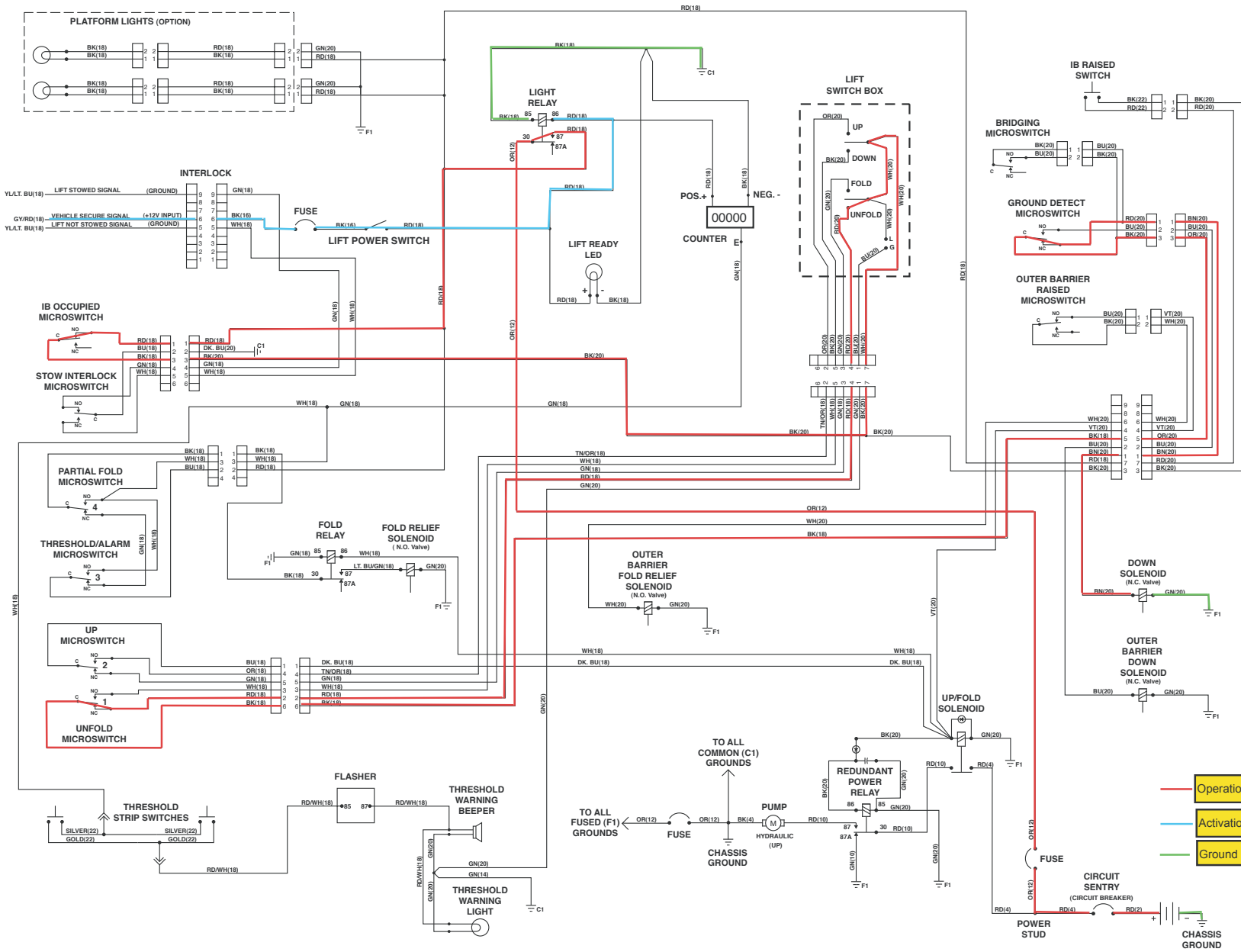

DESCRIPTION	SYMBOL
CAPACITOR	
MICROSWITCH	
DIODE	
FLASHER	
COUNTER	
RELAY	
LIGHT	
BEEPER	
BATTERY	
CHASSIS GROUND	
CIRCUIT BREAKER	
JUNCTION	
MOTOR	
SOLENOID	
SWITCH	
CONNECTER	

NOTES:
 1) JUNCTIONS ONLY OCCUR AT MARKED INTERSECTIONS.

For Reference Only
 By: Jim Pierrou
 Date: 2/22/08

Millennium Down Circuit

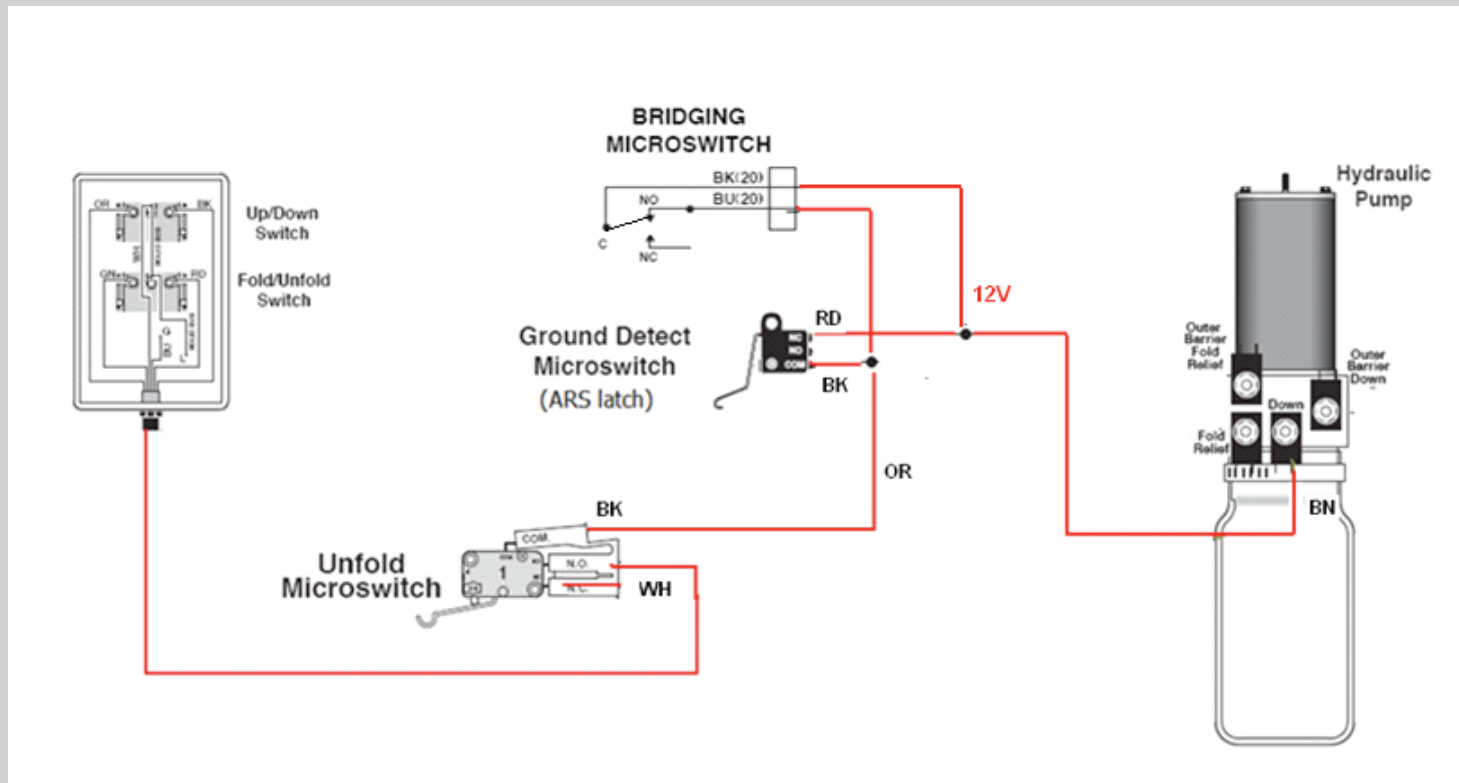

Lift Electrical Schematic

NL -2 Down Schematic

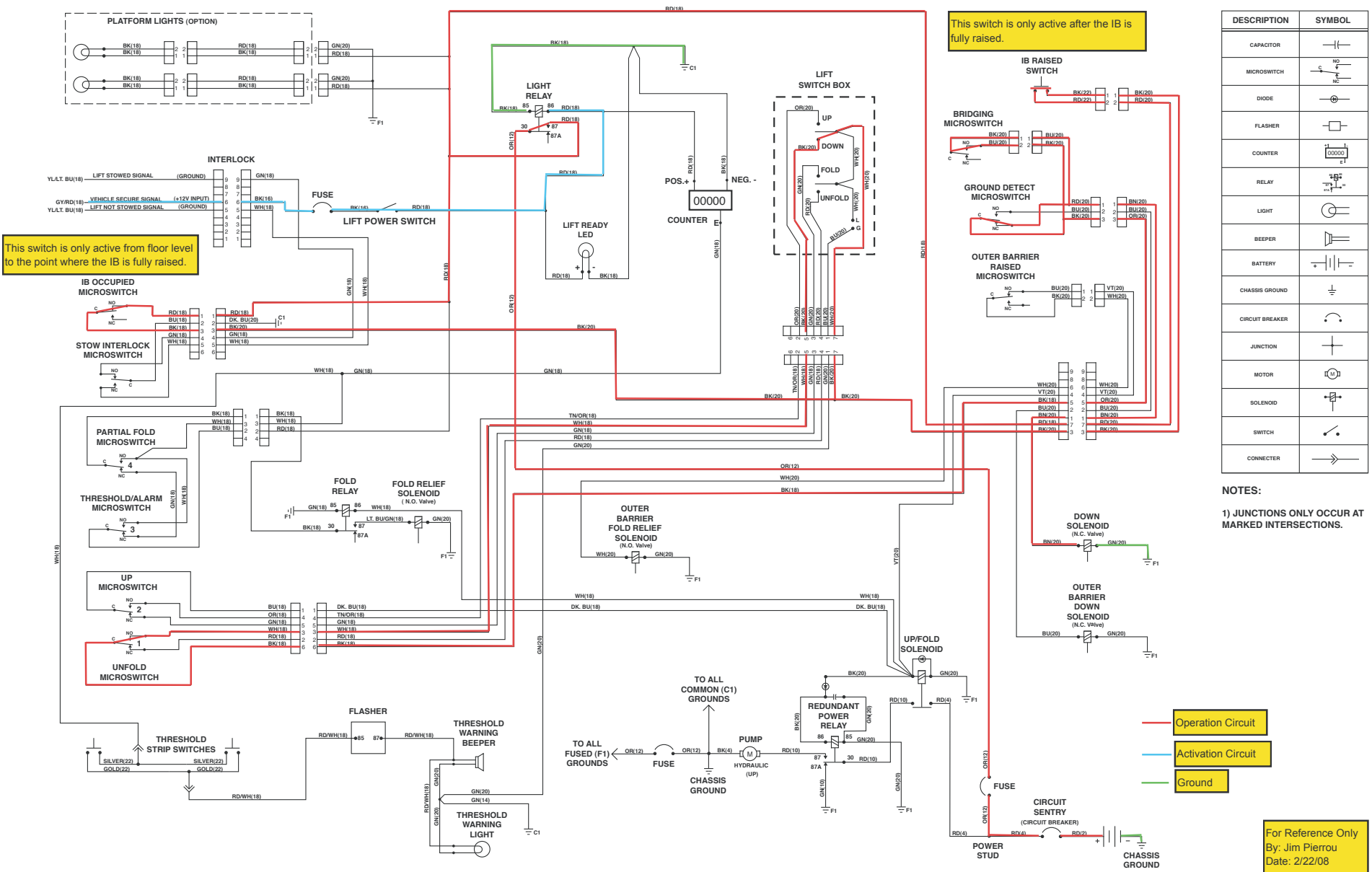

This switch is only active from floor level to the point where the IB is fully raised.

This switch is only active after the IB is fully raised.

DESCRIPTION	SYMBOL
CAPACITOR	
MICROSWITCH	
DIODE	
FLASHER	
COUNTER	
RELAY	
LIGHT	
BEEPER	
BATTERY	
CHASSIS GROUND	
CIRCUIT BREAKER	
JUNCTION	
MOTOR	
SOLENOID	
SWITCH	
CONNECTER	

NOTES:
1) JUNCTIONS ONLY OCCUR AT MARKED INTERSECTIONS.

Operation Circuit
Activation Circuit
Ground

For Reference Only
By: Jim Pierrou
Date: 2/22/08

Millennium Down w/ Barrier Deploying

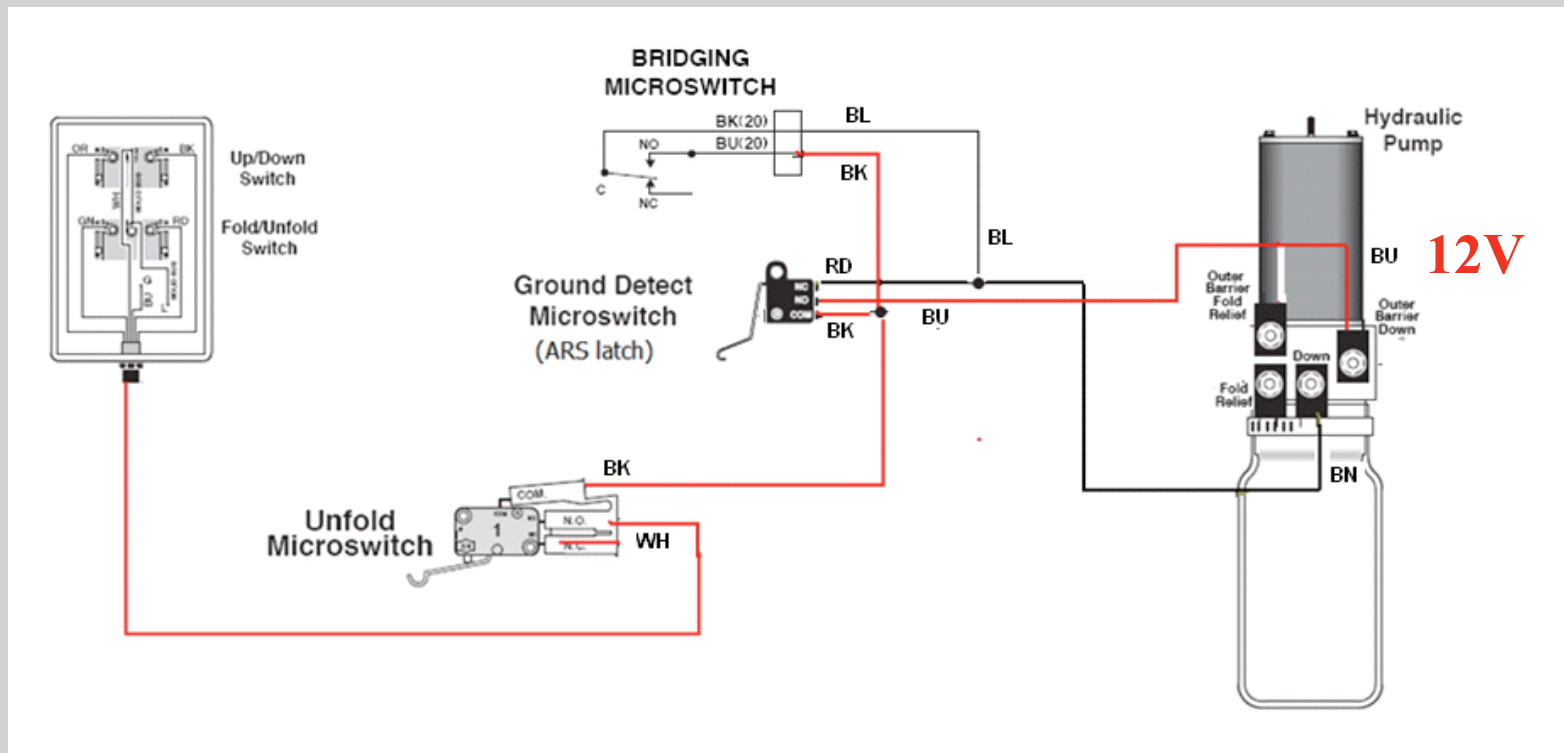

Lift Electrical Schematic

NL -2 Bridge-Rollstop Down Schematic

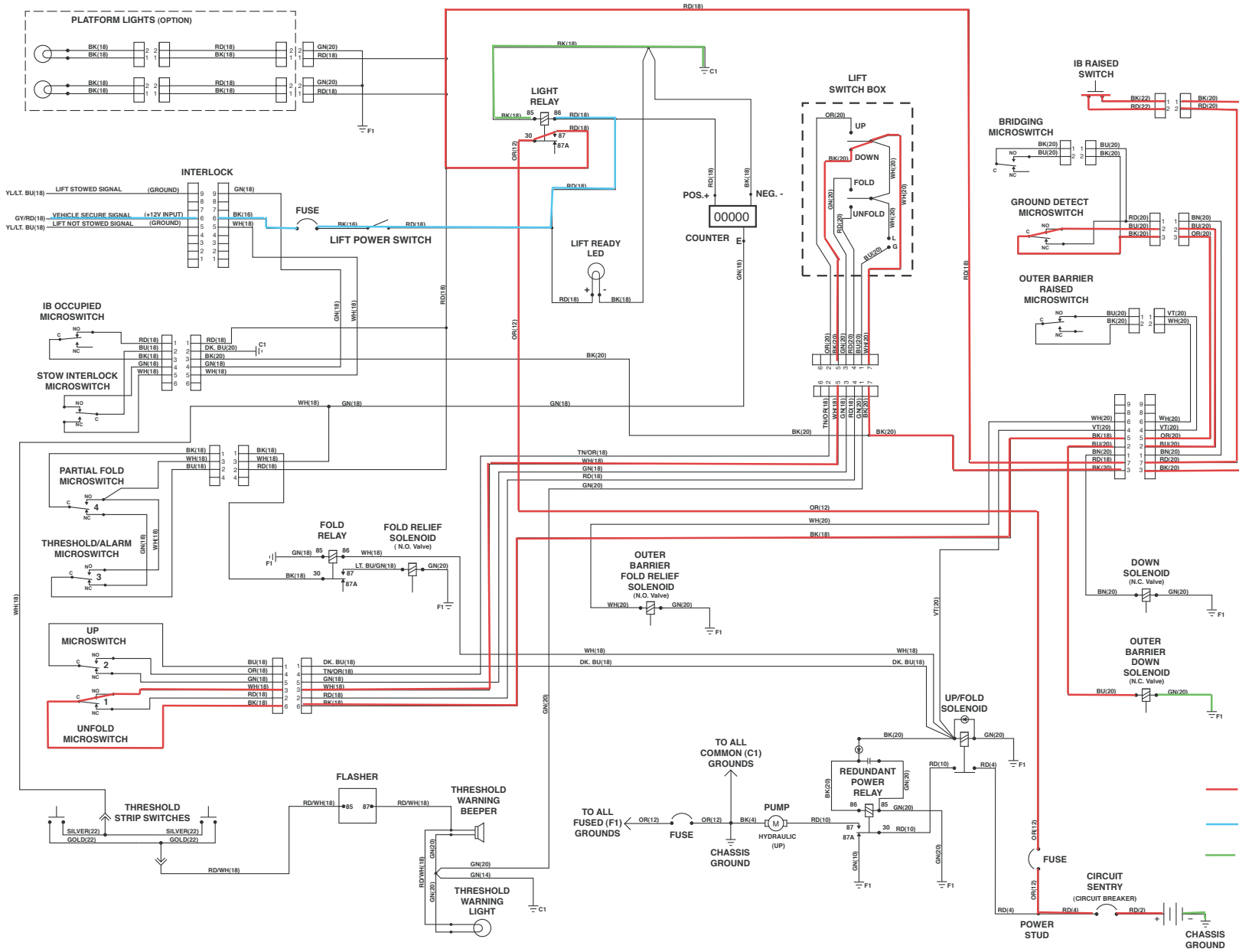

DESCRIPTION	SYMBOL
CAPACITOR	
MICROSWITCH	
DIODE	
FLASHER	
COUNTER	
RELAY	
LIGHT	
BEEPER	
BATTERY	
CHASSIS GROUND	
CIRCUIT BREAKER	
JUNCTION	
MOTOR	
SOLENOID	
SWITCH	
CONNECTER	

NOTES:
1) JUNCTIONS ONLY OCCUR AT MARKED INTERSECTIONS.

- Operation Circuit
- Activation Circuit
- Ground

For Reference Only
By: Jim Pierrou
Date: 2/22/08

Millennium Up with barrier closed circuit

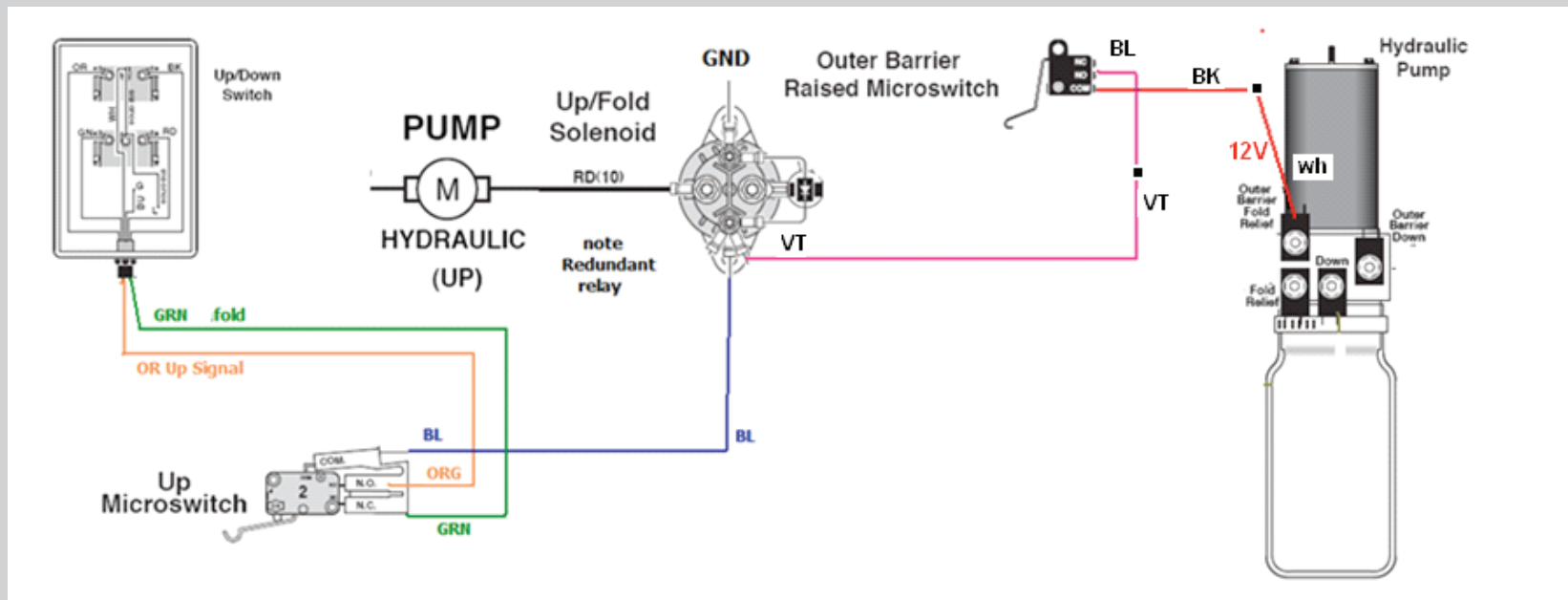

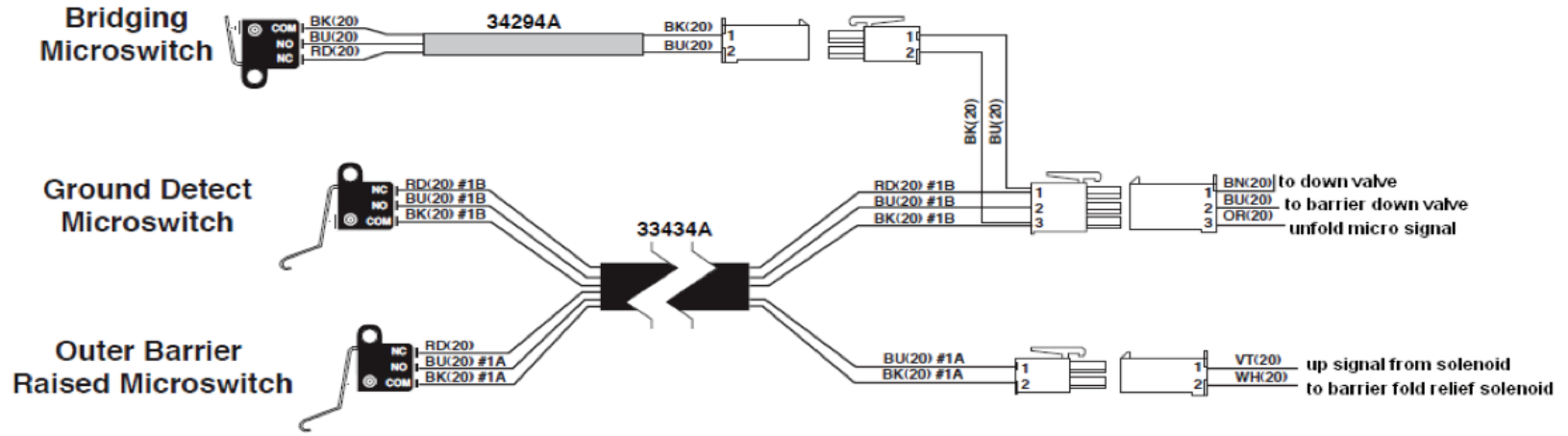

NL Gen-2 platform
limit switch plugs

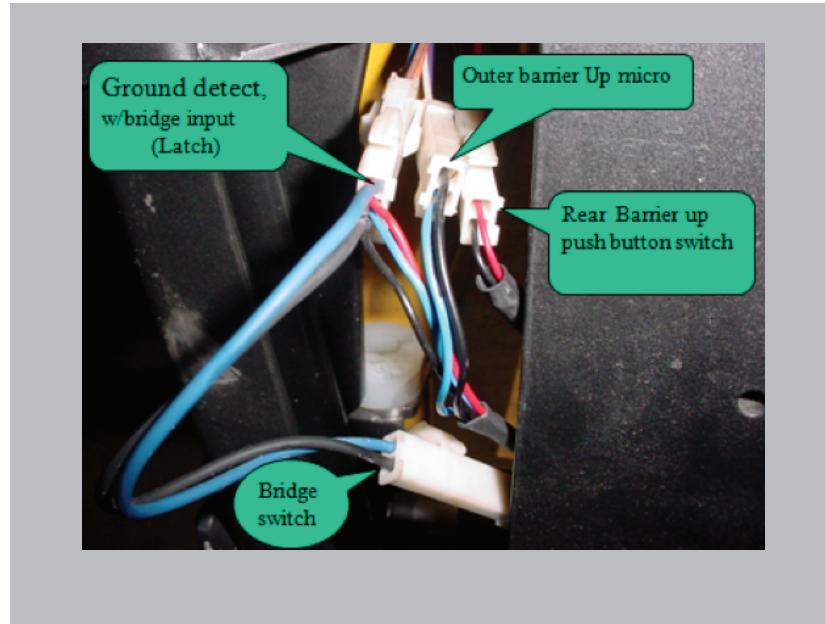

Millennium Up with barrier closed lifting 800lbs

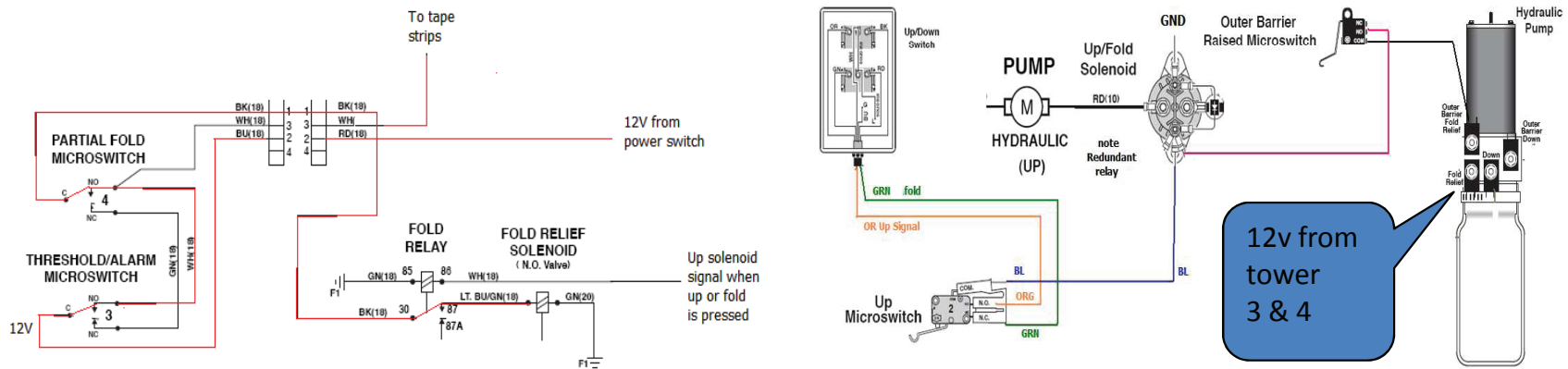

Lift Electrical Schematic

NL -2 Up Schematic

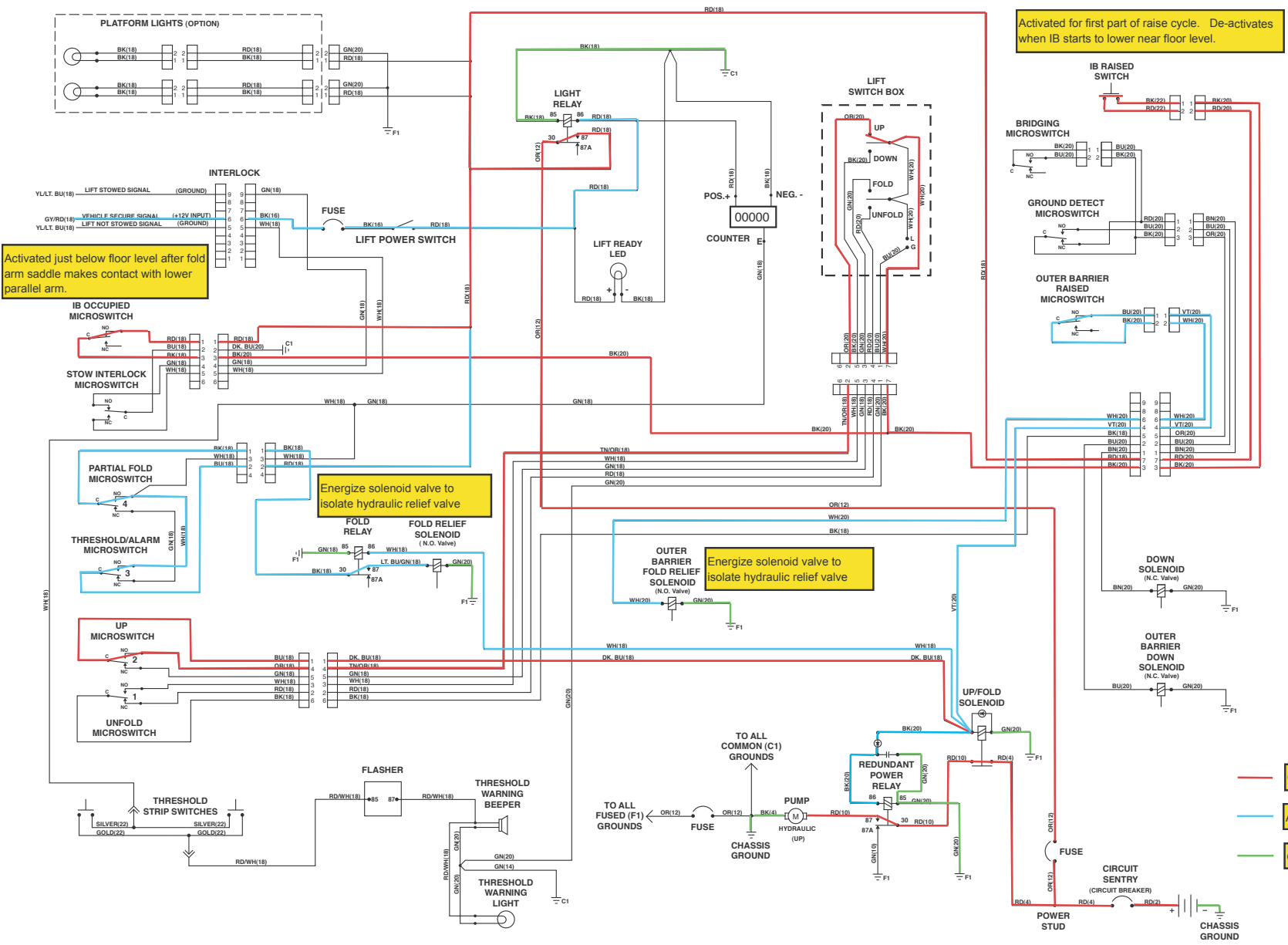

Activated for first part of raise cycle. De-activates when IB starts to lower near floor level.

Activated just below floor level after fold arm saddle makes contact with lower parallel arm.

Energize solenoid valve to isolate hydraulic relief valve

Energize solenoid valve to isolate hydraulic relief valve

DESCRIPTION	SYMBOL
CAPACITOR	
MICROSWITCH	
DIODE	
FLASHER	
COUNTER	
RELAY	
LIGHT	
BEEPER	
BATTERY	
CHASSIS GROUND	
CIRCUIT BREAKER	
JUNCTION	
MOTOR	
SOLENOID	
SWITCH	
CONNECTER	

NOTES:
1) JUNCTIONS ONLY OCCUR AT MARKED INTERSECTIONS.

- Operation Circuit
- Activation Circuit
- Ground

For Reference Only
By: Jim Pierrou
Date: 2/22/08

Electronic Lift Troubleshooting

Lifts built from 2005 to 2008

To better understand the Braun LCD Trouble shooting display you must first understand the numbers that appear on the screen. There are Flashing Codes, Solid Error Codes, and Solid Normal Operational Codes

Flashing Codes #65-89: About 10 seconds after an operation has stopped there are a set of scrolling flashing numbers that indicate whenever a particular sensor or switch has been activated. These numbers will start at number 65 and scroll up to number 89, then start the sequence over. Remember they are not error codes. Keep in mind that the lift will display codes for different positions and certain flashing codes must be present for that position, you will not always get an error code.

Solid Error Codes #50-64: These are the numbers that will come on the screen when the audible and visual alarm goes off, and will direct you to where the problem exists. These numbers will only stay on the screen for about 10 seconds and then the flashing codes will scroll indicating what sensors are active. This sequence of codes will keep repeating. It is important to be looking at the screen when trying to get the lift to fail.

Solid Normal Operational Codes: There are also solid numbers that will appear while and after the lift is moving that indicate the lift operation and platform position.

Troubleshooting Procedures

1. While **looking** at the LCD screen, operate the lift until the failure occurs. Read the number that comes on the display the moment the alarm goes off and the light starts to flash. This code will only stay on the screen for 10 seconds.
2. Look up the number on the correct error code sheet and determine what part on the lift is causing the failure. Go to the part on the lift that is suspected of causing the failure and look for anything obvious like magnets missing, broken wires etc. If nothing is found, the next step is to determine if that sensor is sending a signal to the board.
3. Bring the platform to the level that the sensor should be activated using the backup pump if needed. At this point, look up the flashing code that corresponds to that sensor in the error code sheet, look at the LCD screen and wait for the flashing scrolling numbers to appear. If the number is not included in the scrolling numbers, you know that sensor is the problem. You should then check the harness or try another magnet with the south side of the magnet facing the sensor and see if the number will come up on the display.
4. If the problem is still not found or the harness is suspected, the voltages should be checked to and from the sensor to find the exact location of the problem. First determine the 3 wire colors for this sensor on the board and understand the 3 voltage readings needed to operate the sensor, the 12V power, 8V power, and the 8V input signal to the PC board when activated by a magnet. First check for a 8V input signal coming from the sensor to the wire going into the PC board, if there is 11V on this wire, the sensor is not being activated by the magnet. Next check the 12V and 8V wires at the PC board plug leading to the sensor. Once verified at the plug on the PC board, the voltages should then be checked at the next plug down on the harness going to the sensor until the location of the problem is found.

Anytime you see the code for that specific switch you will have 8 volts on that colored wire on the 8 or 18 pin connector from that switch. IE: Outboard Barrier is closed "72" will appear on the screen and also 8V will be present on the signal wire from that switch, if no code is present the voltage will be 11V.

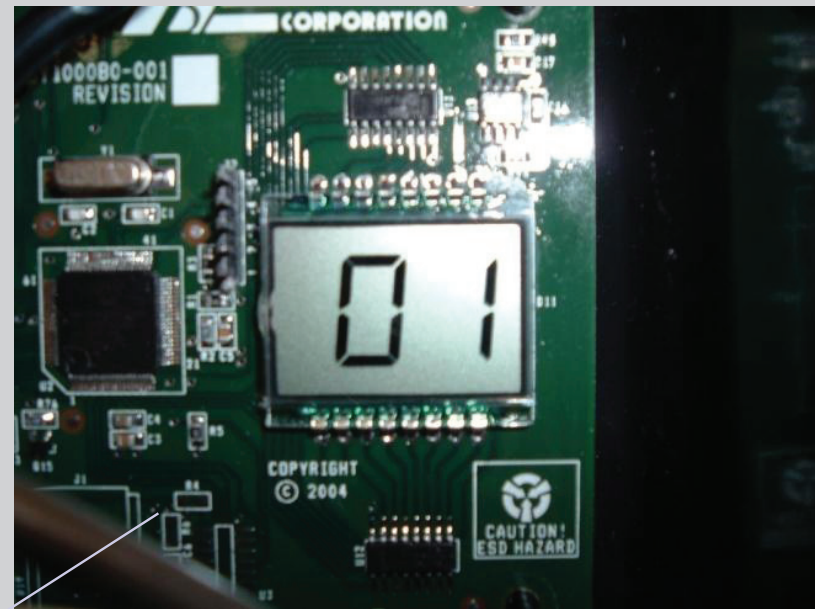

LCD Lift Codes

To better understand the Braun LCD Trouble shooting display you must first understand the numbers that appear on the screen. There are Flashing Codes, Solid Error Codes, and Solid Normal Operational Codes.

Flashing Codes #65-89: About 10 seconds after an operation has stopped there are a set of scrolling flashing numbers that indicate whenever a particular sensor or switch has been activated. These numbers will start at number 65 and scroll up to number 89, then start the sequence over. Remember they are not error codes. Keep in mind that the lift will display codes for different positions and certain flashing codes must be present for that position, you will not always get an error code.

Solid Error Codes #50-64: These are the numbers that will come on the screen when the audible and visual alarm goes off, and will direct you to where the problem exists. These numbers will only stay on the screen for about 10 seconds and then the flashing codes will scroll indicating what sensors are active. This sequence of codes will keep repeating. It is important to be looking at the screen when trying to get the lift to fail.

Solid Normal Operational Codes: There are also solid numbers that will appear while and after the lift is moving that indicate the lift operation and platform position.

Troubleshooting Procedures

1. While **looking** at the LCD screen, operate the lift until the failure occurs. Read the number that comes on the display the moment the alarm goes off and the light starts to flash. This code will only stay on the screen for 10 seconds.
2. Look up the number on the correct error code sheet and determine what part on the lift is causing the failure. Go to the part on the lift that is suspected of causing the failure and look for anything obvious like magnets missing, broken wires etc. If nothing is found, the next step is to determine if that sensor is sending a signal to the board.
3. Bring the platform to the level that the sensor should be activated using the backup pump if needed. At this point, look up the flashing code that corresponds to that sensor in the error code sheet, look at the LCD screen and wait for the flashing scrolling numbers to appear. If the number is not included in the scrolling numbers, you know that sensor is the problem. You should then check the harness or try another magnet with the south side of the magnet facing the sensor and see if the number will come up on the display.
4. If the problem is still not found or the harness is suspected, the voltages should to be checked to and from the sensor to find the exact location of the problem. First determine the 3 wire colors for this sensor at the board and understand the 3 voltage readings needed to operate the sensor, the 12V power, 8V power, and the 8V input signal to the PC board when activated by a magnet. First check for a 8V input signal coming from the sensor to the wire going into the PC board, if there is 11V on this wire, the sensor is not being activated by the magnet. Next check the 12V and 8V wires at the PC board plug leading to the sensor. Once verified at the plug on the PC board, the voltages should then be checked at the next plug down on the harness going to the sensor until the location of the problem is found.

Anytime you see the code for that specific switch you will have 8 volts on that colored wire on the 8 or 18 pin connector from that switch. IE: Outboard Barrier is closed "72" will appear on the screen and also 8V will be present on the signal wire from that switch, if no code is present the voltage will be 11V.

LCD Lift Codes

Listed below are codes that the lift controller outputs during lift operation. The codes will be displayed on an LCD screen located on the lift control board inside the pump module. See the Manual Operating Instructions in the operator's manual for pump cover removal instructions.

Non-Flashing Numbers

- 01 – Platform stowed
- 02 – Platform unfolding
- 03 – Platform unfolding paused
- 04 – Platform at floor level
- 05 – Platform beginning to lower
- 06 – Platform lowering (threshold cannot be occupied from this point down)
- 07 – Outer barrier moving to horizontal position
- 08 – Platform at ground level
- 09 – Outer barrier moving to vertical position
- 10 – Platform raising
- 11 – Platform raising paused at floor
- 12 – Platform folding (limited pressure)
- 13 – Platform folding (full pressure)
- 14 – Timed fold (cinching lift tite) or (anti-rattle state)
- 15 – Platform folding stopped
- 16 – Paused fold
- 17 – Platform between ground and 3" above ground
- 18 – Platform above 3"
- 19 – Outer barrier moving to horizontal position
- 23 – Outer barrier going back down after occupant detected
- 28 – Illegal function/not defined
- 29 – Interlock fault not recognized (or has been cleared but a motion button is still pressed)
- 30 – Platform location unknown
- 31 – Platform location transition state; attempting to locate position
- 35 – Two or more motion buttons are being pressed
- 36 – The retention belt cannot be buckled while trying to fold or unfold
- 37 – Motion button being pressed is not a valid motion
- 50 – Outer barrier is not up above inboard barrier locked position
- 51 – Threshold is occupied when platform is 1" or more below floor level
- 52 – Inner roll stop is not up and locked below inner roll stop locked position
- 53 – Inner roll stop occupied sensor is not activated between floor and inner roll stop up position
- 54 – Outer barrier is occupied before it is up
- 55 – Outer barrier is not latched when above the inner roll stop locked position (Millennium only)
- 56 – Outer barrier is not up and latched and bridge switch did not deactivate
- 57 – Outer barrier is not up and latched and ground detect switch did not deactivate (Century and Vista only)
- 58 – Outer barrier is not up and latched and the platform is 3" above the ground
- 59 – Outer barrier is not up after pausing platform travel
- 60 – Verify the IB occupied switch is functioning correctly when lift is below floor level. The knockout gas springs might be worn, replace before using.
- 75 – Low voltage detected; must turn off power switch to reset LCD
- 77 – Vehicle secure interlock has not been activated
- 90 – Position will be set if you keep holding the button until it beeps
- 91 – Position is out of a predetermined acceptable range of floor position
- 92 – Bridge switch is not made, needs adjusting
- 93 – Inner roll stop occupied switch is not made, position needs to be moved or switch should be adjusted
- 94 – Outer barrier is not made, fix and try again
- 95 – Outer barrier latch is not made (check for jumper on Century and Vista lifts, check latch on Millennium lifts)
- 99 – Controller program is not valid; replace controller

Flashing Numbers

- Flashing 65 – Unfold button is pressed
- Flashing 66 – Fold button is pressed
- Flashing 67 – Down button is pressed
- Flashing 68 – Up button is pressed
- Flashing 69 – Bridge switch is activated
- Flashing 70 – Outer barrier latch switch is activated
- Flashing 71 – Ground detect switch is activated
- Flashing 72 – Outer barrier up switch is activated
- Flashing 73 – Inner roll stop up switch is activated
- Flashing 74 – Inner roll stop occupied switch is activated
- Flashing 76 – Outboard barrier occupied switch is activated
- Flashing 78 – Threshold tape switch "A" is activated
- Flashing 79 – Threshold tape switch "B" is activated
- Flashing 80 – Position set button is pressed

SOUTH POLE MUST FACE SWITCH

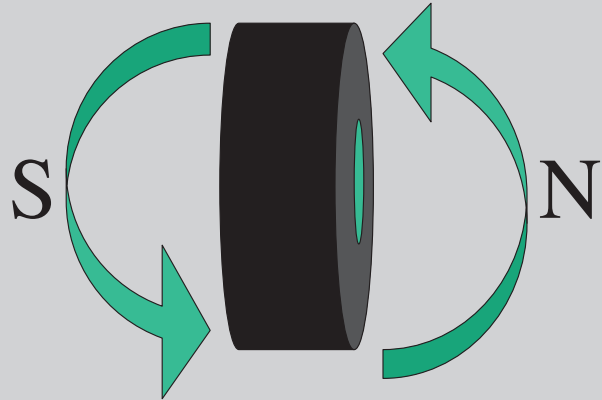

If a sensor is not working make sure the south side of the magnet is facing the sensor. The sensor will have a white dot on the south side.

Sensor logic

- 8 volt input
- 12 Volt input to operate components in sensor
- 8 Volt output when sensor is activated

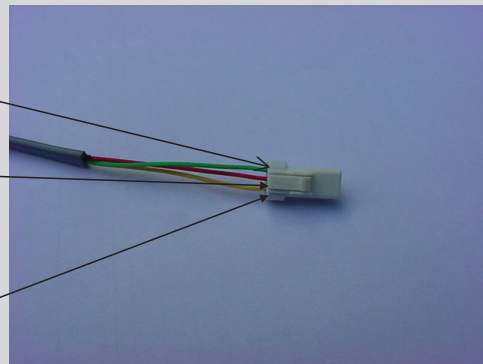

Remember the yellow wire is always the signal wire on every sensor.

Rollstop Raised Probing yellow wire

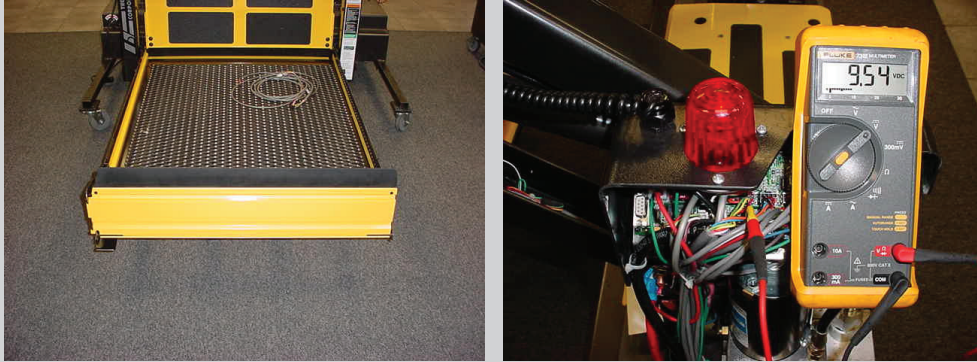

Understand the difference between 8v and 12v volts when checking the signal from the sensor. 8 or 9 volts when the sensor is activated.

Rollstop Deployed Probing yellow wire

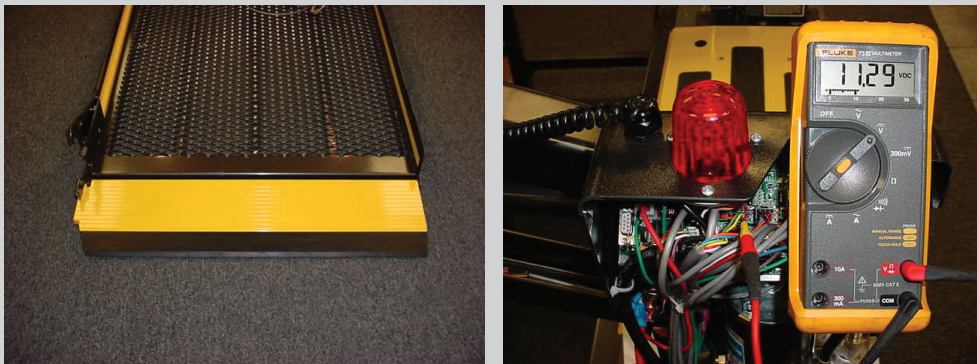

Then 11 to 12 volts when the sensor is not activated. Remember the 11 volts you see is a back feed from the circuit board.

Lift Condition	Millenium with Rotary Encoder Series 02 - C5								
	Bridge Codes	OB Latched	Ground Detect	OB Barrier	IB Raised jumper	IB Occupied	OB Barrier Occupied	Threshold(A) Occupied	Threshold (B) Occupied
Stowed		70	71	72	73	74	76		
Free Fold Zone		70	71	72	73	74	76		
Occupant Detect Zone		70	71	72	73	74	76		
Floor Level	69	70	71	72	73	74	76		
1" Below Floor Level	69	70	71	72	73	74	76	78	79
Inner Roll Stop Locked	69	70	71	72	73		76	78	79
1 Foot Off Ground	69	70	71	72	73		76	78	79
Ground Level (Not Bridged)	69		71		73		76	78	79
Ground Level (Bridged)			71		73		76	78	79

Lift Condition	Century with Rotary Encoder Series 02 - C5								
	Bridge Codes	OB Latched	Ground Detect	RS Rained	IB Raised jumper	IB Occupied	OB Barrier Occupied	Threshold(A) Occupied	Threshold (B) Occupied
Stowed		70		72	73	74	76		
Free Fold Zone		70		72	73	74	76		
Occupant Detect Zone		70		72	73	74	76		
Floor Level	69	70		72	73	74	76		
1" Below Floor Level	69	70		72	73	74	76	78	79
Inner Roll Stop Locked	69	70		72	73		76	78	79
1 Foot Off Ground	69	70		72	73		76	78	79
Ground Level (Not Bridged)	69	70	71		73		76	78	79
Ground Level (Bridged)		70	71		73		76	78	79

Lift Condition	Vista with Rotary Encoder Series 02 - C5								
	Bridge Codes	OB Latched	Ground Detect	RS Raised	IB Raised jumper	IB Occupied	OB Barrier Occupied	Threshold(A) Occupied	Threshold (B) Occupied
Stowed		70			73	74	76		
Free Fold Zone		70			73	74	76		
Occupant Detect Zone		70			73	74	76		
Floor Level	69	70		72	73	74	76		
1" Below Floor Level	69	70		72	73	74	76	78	79
Inner Roll Stop Locked	69	70		72	73		76	78	79
1 Foot Off Ground	69	70		72	73		76	78	79
Ground Level (Not Bridged)	69	70	71		73		76	78	79
Ground Level (Bridged)		70	71		73		76	78	79

Braun® Limited Warranty For Dual Parallel Arm Public Use Lifts

WARRANTY COVERAGE AND WARRANTY COVERAGE TIME PERIODS

The Braun Corporation (“Braun”) warranty covers certain parts of this wheelchair lift for three (3) years or 10,000 cycles and the cost of labor to repair or replace those parts for one (1) year or 3,000 cycles. If The Braun Corporation receives the warranty registration card within 20 days after the lift is put into service, the warranty labor coverage will increase from one (1) year or 3,000 cycles to three (3) years or 10,000 cycles. In addition, providing the warranty registration card is returned as noted above, the following lift’s power train parts are warrantied for five (5) years or 15,000 cycles: Cable, Cylinder, Flow Control, Gear Box, Motor, Pump, Hydraulic Hose and Fittings. This limited warranty covers substantial defects in materials and workmanship of the lift, provided that the lift is operated and maintained properly and in conformity with the owner’s manual. The warranty period begins on the date that the product is delivered to the first retail purchaser by an independent, authorized dealer of Braun, or, if the dealer places the product into any type of service prior to retail sale, on the date the dealer first places the product in such service. This limited warranty applies only to the first purchaser. It may not be transferred.

WHAT BRAUN WILL DO TO CORRECT PROBLEMS

In the event that a substantial defect in material or workmanship, attributable to Braun, is found to exist during the first year of warranty coverage, it will be repaired or replaced, at Braun’s option, without charge for parts or labor to the owner, in accordance with the terms, conditions and limitations of this limited warranty. If the substantial defect in material or workmanship, attributable to Braun, is found to exist during the second or third year of warranty coverage, it will be repaired or replaced, at Braun’s option, without charge to the owner for parts, only, in accordance with the terms, conditions and limitations of this limited warranty. Providing the warranty card is returned within 20 days as outlined above, the labor warranty period will be extended by two years of coverage in accordance with the terms, conditions, and limitations of this limited warranty. In addition, if a substantial defect in material or workmanship, attributable to Braun, is found to exist during the fourth or fifth year of warranty coverage to the following lift’s power train parts: Cable, Cylinder, Flow Control, Gear Box, Motor, Pump, Hydraulic Hose and Fittings, it will be repaired or replaced, at Braun’s option, without charge to the owner for parts, only, in accordance with the terms, conditions and limitations of this limited warranty. The cost of labor for repair or replacement at any time after the warranty coverage detailed above is the sole responsibility of the owner.

Braun’s obligation to repair or replace defective materials or workmanship is the sole obligation of Braun under this limited warranty. Braun reserves the right to use new or remanufactured parts of similar quality to complete any work, and to make parts and design changes from time to time without notice to anyone. Braun reserves the right to make changes in the design or material of its products without incurring any obligation to incorporate such changes in any previously manufactured product. Braun makes no warranty as to the future performance of this product, and this limited warranty is not intended to extend to the future performance of the product. In addition, the owner’s obligation to notify Braun, or one of its authorized, independent dealers, of a claimed defect does not modify any obligation placed on the owner to contact Braun directly when attempting to pursue remedies under state or federal law.

LIMITATIONS, EXCLUSIONS AND DISCLAIMER OF IMPLIED WARRANTIES

ANY IMPLIED WARRANTY THAT IS FOUND TO ARISE BY WAY OF STATE OR FEDERAL LAW, INCLUDING ANY IMPLIED WARRANTY OF MERCHANTABILITY OR ANY IMPLIED WARRANTY OF FITNESS, IS LIMITED IN DURATION TO THE TERMS OF THIS LIMITED WARRANTY AND IS LIMITED IN SCOPE OF COVERAGE TO THE SCOPE OF COVERAGE OF THIS LIMITED WARRANTY. Braun disclaims any express or implied warranty, including any implied warranty of fitness or merchantability, on items excluded from coverage as set forth in this limited warranty. Braun makes no warranty of any nature beyond that contained in this limited warranty. No one has authority to enlarge, amend or modify this limited warranty, and Braun does not authorize anyone to create any other obligation for it regarding this product. Braun is not responsible for any representation, promise or warranty made by any independent dealer or other person beyond what is expressly stated in this limited warranty. Any selling or servicing dealer is not Braun’s agent, but an independent entity.

Braun® Limited Warranty For Dual Parallel Arm Public Use Lifts

BRAUN SHALL NOT BE LIABLE FOR ANY INCIDENTAL OR CONSEQUENTIAL DAMAGES THAT MAY RESULT FROM BREACH OF THIS LIMITED WARRANTY OR ANY IMPLIED WARRANTY. THIS EXCLUSION OF CONSEQUENTIAL AND INCIDENTAL DAMAGES SHALL BE INDEPENDENT OF ANY FAILURE OF THE ESSENTIAL PURPOSE OF ANY WARRANTY, AND THIS EXCLUSION SHALL SURVIVE ANY DETERMINATION THAT THIS LIMITED WARRANTY OR ANY IMPLIED WARRANTY HAS FAILED OF ITS ESSENTIAL PURPOSE. This warranty does not cover, and in no event shall Braun be liable for towing charges, travel, lodging, or any other expense incurred due to the loss of use of the product or other reason.

Some states do not allow limitations on how long an implied warranty lasts, or the exclusion or limitation of incidental or consequential damages, so the above limitations or exclusions may not apply to you.

HOW TO GET SERVICE

To obtain warranty service the owner must do all of the following:

1. Notify an authorized service center, of the claimed defect attributable to Braun, within the warranty coverage period designated above
2. Provide the notification mentioned in (1), above, within ten (10) days of when the owner discovered, or should have discovered, the claimed defect
3. Promptly schedule an appointment with and take the product to an authorized service center for service.
4. Pay any transportation costs and all expenses associated with obtaining warranty service.

Since Braun does not control the scheduling of service work at the independent dealerships you may encounter some delay in scheduling or completion of work. If you need assistance you may contact Braun, at 631 West 11th Street, Winamac, Indiana 46996; 1-800-THE-LIFT, (843-5438).

If two (2) or more service attempts have been made to correct any covered defect that you believe impairs the value, use or safety of the product, or if it has taken longer than thirty (30) days for repairs to be completed, you must, to the extent permitted by law, notify Braun directly, in writing, at the above address, of the unsuccessful repair(s) of the alleged defect(s) so that Braun can become directly involved in providing service pursuant to the terms of this limited warranty.

WHAT IS NOT COVERED

This Limited Warranty does not cover any of the following: defects in materials, components or parts of the product not attributable to Braun, any material, component or part of the product that is warranted by another entity (Note: the written warranty provided by the manufacturer of the material, component or part is the direct responsibility of that manufacturer); items that are added or changed after the product leaves Braun's possession; additional items installed at any dealership, or other place of business, or by any other party, other than Braun; normal wear, tear, usage, maintenance, service, periodic adjustments, the effects of condensation or moisture from condensation; mold or any damage caused by mold; imperfections that do not affect the product for its intended purpose; items that are working as designed but that you are unhappy with; problems related to mis-operation, misuse, mishandling, neglect or abuse, including failure to maintain the product in accordance with the owner's manual, or other routine maintenance such as inspections, lubricating, adjustments, tightening of screws, sealing, wheel alignments or rotating tires; damage due to accident or collision, including any acts of weather or damage or corrosion due to the environment; theft, vandalism, fire, or other intervening acts not attributable to Braun; damage resulting from tire wear or tire failure; defacing, scratches, dents or chips on any interior or exterior surface of the product, including those caused by rocks or other road hazards, damage caused by off road use, overloading or alteration of the product, or any of its components or parts.

Defects and/or damage to interior and exterior surfaces and other appearance items may occur at the factory or when the product is in transit. These items are usually detected and corrected at the factory or by

Braun® Limited Warranty For Dual Parallel Arm Public Use Lifts

a dealer prior to delivery to the purchaser. You must inspect the product for this type of damage when you take delivery. If you find any such defect or damage you must notify the selling dealer, or Braun, at the time of delivery to have these items covered by this limited warranty and to have work performed on the items at no cost to you as provided by this limited warranty.

EVENTS DISCHARGING BRAUN FROM OBLIGATION UNDER WARRANTY

The following shall completely discharge Braun from any express or implied warranty obligation to repair or replace anything and void this warranty: misuse, neglect, collision, accidents, failure to provide routine maintenance (See Owner's Manual), unauthorized alteration, off road use, Acts of Nature, damage from weather or the environment, theft, vandalism, tampering, fire, explosions, overloading the product and odometer tampering.

LEGAL REMEDIES

Any action to enforce any portion of this limited warranty, or any implied warranty, must be commenced within six (6) months after expiration of the warranty coverage period designated above or the action will be barred because of the passage of time. Any performance of repairs shall not suspend this limitation period from expiring. Any performance of repairs after the warranty coverage period has expired, or performance of repairs regarding any thing excluded from coverage under this limited warranty shall be considered "good will" repairs, and they will not alter the terms of this limited warranty, or extend the warranty coverage period or the filing limitation period in this paragraph. In addition, since it is reasonable to expect that the product will need some service during the warranty period; this warranty does not extend to future performance. It only sets forth what Braun will do and does not guarantee anything about the product for any time period. Nothing in this warranty, or any action of Braun, or any agent of Braun, shall be interpreted as an extension of any warranty period or the filing limitation period in this paragraph. Some states do not allow a reduction in the statute of limitations, so this reduction may not apply to you.

WARRANTY REGISTRATION and MISCELLANEOUS

Your warranty registration records should be completed and delivered to the appropriate companies, including the Braun Delivery Checklist & Warranty form. That form must be returned to Braun within twenty (20) days of purchase. The Braun warranty will not be registered unless this warranty registration is completed and received by Braun. Failure to file this warranty registration with Braun will not affect your rights under this limited warranty as long as you can present proof of purchase, but it can cause delays in obtaining the benefits of this limited warranty, and it changes the start date of the warranty to the date of final assembly of the product by Braun.

Braun agrees to repair or replace any of its factory installed parts found to have substantial defects within the appropriate warranty period designated above, provided that the repair is authorized by Braun and carried out by an authorized service center (a Braun labor schedule determines the cost allowance for repairs). Braun will not honor any warranty claim for repairs or replacement of parts unless the claim is submitted with the appropriate paperwork, and the work is completed by an independent, factory authorized service center. The appropriate paperwork can be obtained by written or phone contact with Braun at the contact information in this warranty.

Braun reserves the right to designate where any warranty work can be performed. Braun also reserves the right to examine any defective workmanship or part prior to giving any authorization for warranty work. Braun's return authorization procedure must be adhered to in order to process any warranty claims.

THIS WARRANTY GIVES YOU SPECIFIC LEGAL RIGHTS. YOU MAY ALSO HAVE OTHER RIGHTS THAT VARY FROM STATE TO STATE.